

Product Specification

*Single LC 155Mb/s 15Km 1310nm Tx/1550nm Rx
BIDI SFP Transceiver*

EBSP155-3155LXSN

ePHOTON

Ver A

EBSP155-3155LXSN

Single LC 155Mb/s 15Km 1310nm Tx/1550nm Rx

BIDI SFP Transceiver

1 Features

- 1.1 Single LC receptacle optical interface compliant
- 1.2 Serial ID module on MOD(0-2)
- 1.3 Hot-pluggable
- 1.4 Transmitter disable input
- 1.5 +3.3V Single power supply
- 1.6 Operate data rate from 50Mb/s to 200Mb/s
- 1.7 International Class 1 laser safety certified
- 1.8 AC Coupling of PECL signals
- 1.9 LVTTTL logic level RX LOS
- 1.10 With pull de-latch
- 1.11 Links of 15 km with 9/125 μ m single mode fiber (SMF) of maximum interconnect distances
- 1.12 Complies with RoHS directive (2002/95/EC)
- 1.13 -5~75°C Case Operate Temperature Range

2 Applications

- 2.1 SDH/SONET
- 2.2 ATM
- 2.3 Fast Ethernet

3 General

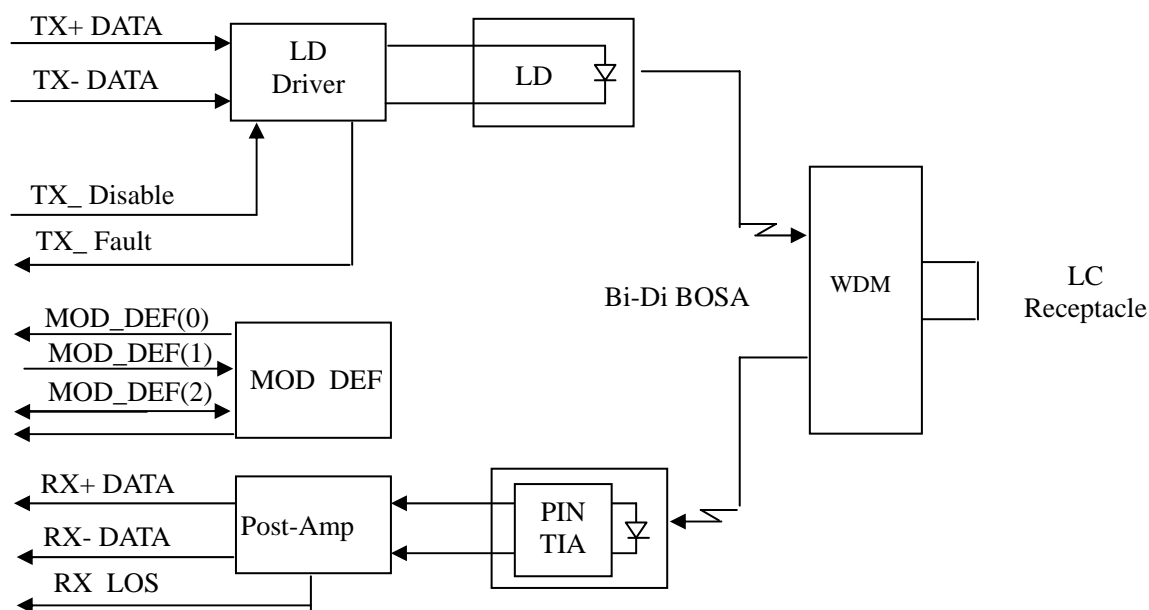

3.1 Transmitter Section

Transmitter is designed for single mode fiber and operates at a nominal wavelength of 1310nm. The transmitter module uses a FP laser diode and full IEC825 and CDRH class 1 eye safety. The output power can be disabled via the single TX Disable pin. Logic LVTTTL HIGH level disables the transmitter. It contains APC function, temperature compensation circuit, PECL data inputs, LVTTTL TX Disable input and TX Fault output interface.

3.2 Receiver Section

The receiver section uses a hermetic packaged front end receiver (InGaAs PIN and preamplifier).The post amplifier is ac coupled to preamplifier through a capacitor and a low pass filter. The capacitor and LPF are enough to pass the signal from 10Mb/s to 155Mb/s without significant distortion or performance penalty. The LPF limits the preamplifier bandwidth to improve receiver sensitivity. As the input optical is decreased, LOS will switch from low to high. As the input optical power is increased from very low levels, LOS will switch back from high to low.

3.3 EEPROM Section

The optical transceiver contains an EEPROM. It provides access to sophisticated identification information that describes the transceiver’s capabilities, standard interfaces, manufacturer, and other information.

The serial interface uses the 2-wire serial CMOS EEPROM protocol defined for the ATMEL AT24C01A/02/04 family of components. When the serial protocol is activated, the host generates the serial clock signal (SCL, Mod Def 1). The positive edge clocks data into those segments of the EEPROM that are not write-protected within the SFP transceiver. The negative edge clocks data from the SFP transceiver. The serial data signal (SDA, Mod Def 2) is bi-directional for serial data transfer. The host uses SDA in conjunction with SCL to mark the start and end of serial protocol activation. The memories are organized as a series of 8-bit data words that can be addressed individually or sequentially.

2 wire address 1010000X (A0h)

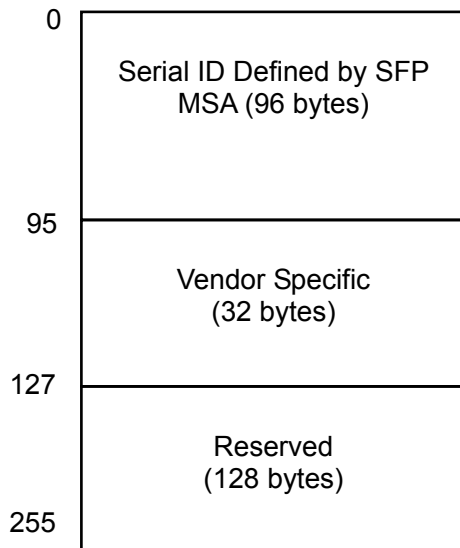

4 Performance Specifications

4.1 Absolute Maximum Ratings

Parameter	Symbol	Min.	Max.	Unit
Storage Temperature (Non-Operating)	Tstg	-40	+85	°C
Case Temperature (Operating)	Tc	-5	+75	°C
Input Voltage	-	GND	Vcc	V
Power Supply Voltage	Vcc-Vee	-0.5	+3.6	V

4.2 Recommended Operating Conditions

Parameter	Symbol	Min.	Typ.	Max.	Unit	Note
Power Supply Voltage	Vcc	+3.1	+3.3	+3.5	V	-
Power Supply Current	Icc	-	200	300	mA	-
Case Temperature (Operating)	Tc	-5	-	75	°C	-
Data Rate	-	-	155	-	Mb/s	-

4.3 Transmitter E-O characteristics

Parameter	Symbol	Min.	Typ.	Max.	Unit	Note
Center Wavelength	λ	1260	1310	1360	nm	-
Spectral Width (RMS)	$\Delta \lambda$	-	-	6	nm	-
Average Optical Output Power	Po	-15	-	-8	dBm	-
Extinction Ratio	Er	10	-	-	dB	-
Transmitter Enable Voltage	VEN	0	-	0.8	V	-
Transmitter Disable Voltage	VD	2.0	-	Vcc	V	-
Single Ended Data Input Swing	V _{INPP}	250	-	1200	mV	-
Output Eye Diagram	Compliant with ITU recommendation G.957					

4.4 Receiver O-E Characteristics

Parameter	Symbol	Min.	Typ.	Max.	Unit	Note
Operate Wavelength	-	1480	-	1600	nm	-
Sensitivity	Sen	-	-	-31	dBm	1
Saturation	Psat	-3	-	-	dBm	1
LOS Asserted	-	-43	-	-	dBm	High Level: Alarm
LOS De-Asserted	-	-	-	-32	dBm	
LOS Hysteresis	-	0.5	3	-	dB	
Single Ended Data Output Swing	Voutpp	185	-	1000	mV	-
LOS Low Voltage	Vlout	-	-	0.8	V	-
LOS High Voltage	Vhout	2.0	-	-	V	-

Notes:

1. Minimum sensitivity and saturation levels for a $2^{23}-1$ PRBS with 72 ones and 72 zeros inserted (ITU recommendation G958)

5 Pin Definitions

5.1 Pin Diagram

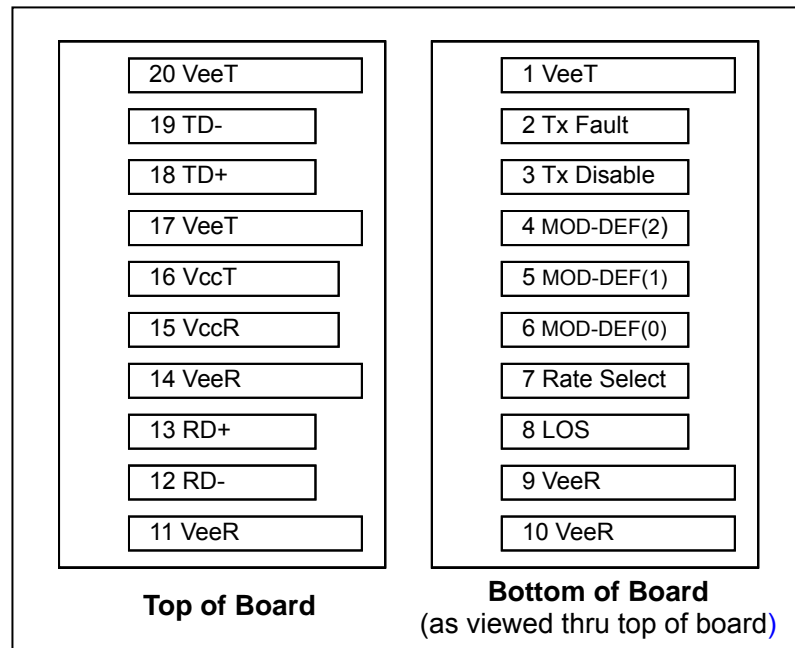

5.2 Pin Descriptions

Pin#	Name	Function	Notes
1	VeeT	Transmitter Ground	-
2	Tx Fault	Transmitter Fault Indication	Note 1
3	Tx Disable	Transmitter Disable	Note 2, Module disables on high or open
4	MOD DEF(2)	Module Definition 2	Note 3, 2 wire serial ID interface
5	MOD DEF(1)	Module Definition 1	Note 3, 2 wire serial ID interface
6	MOD DEF(0)	Module Definition 0	Note 3, Grounded in Module
7	Rate Select	Not Use	-
8	LOS	Loss of Signal	Note 4
9	VeeR	Receiver Ground	Note 5
10	VeeR	Receiver Ground	Note 5
11	VeeR	Receiver Ground	Note 5
12	RD-	Inv. Received Data Out	Note 6
13	RD+	Received Data Out	Note 6
14	VeeR	Receiver Ground	Note 5
15	VccR	Receiver Power	Note 7, 3.3V 5%
16	VccT	Transmitter Power	Note 7, 3.3V 5%
17	VeeT	Transmitter Ground	Note 5
18	TD+	Transmitter Data In	Note 8
19	TD-	Inv. Transmitter Data In	Note 8
20	VeeT	Transmitter Ground	Note 5

Notes:

1. TX Fault is an open collector/drain output, which should be pulled up with a 4.7K–10K Ω resistor on the host board. Pull up voltage between 2.0V and VccT, R+0.3V. When high, output indicates a laser fault of some kind. Low indicates normal operation. In the low state, the output will be pulled to < 0.8V.
2. TX disable is an input that is used to shut down the transmitter optical output. It is pulled up within the module with a 4.7–10 K Ω resistor. Its states are:
Low (0–0.8V): Transmitter on
(>0.8, <2.0V): Undefined
High (2.0–3.465V): Transmitter Disabled
Open: Transmitter Disabled
3. Mod-Def 0,1,2. These are the module definition pins. They should be pulled up with a 4.7K–10K Ω resistor on the host board. The pull-up voltage shall be VccT or VccR.
Mod-Def 0 is grounded by the module to indicate that the module is present
Mod-Def 1 is the clock line of two wire serial interface for serial ID
Mod-Def 2 is the data line of two wire serial interface for serial ID
4. LOS (Loss of Signal) is an open collector/drain output, which should be pulled up with a 4.7K–10K Ω resistor. Pull up voltage between 2.0V and VccT, R+0.3V. When high, this output indicates the received optical power is below the worst-case receiver sensitivity (as defined by the standard in use). Low indicates normal operation. In the low state, the output will be pulled to < 0.8V.
5. VeeR and VeeT may be internally connected within the SFP module.
6. RD-/+ : These are the differential receiver outputs. They are AC coupled 100 Ω differential lines which should be terminated with 100 Ω (differential) at the user SERDES. The AC coupling is done inside the module and is thus not required on the host board.
7. VccR and VccT are the receiver and transmitter power supplies. They are defined as 3.3V \pm 5% at the SFP connector pin. Maximum supply current is 300mA. Recommended host board power supply filtering is shown below. Inductors with DC resistance of less than 1 Ω should be used in order to maintain the required voltage at the SFP input pin with 3.3V supply voltage. When the recommended supply filtering network is used, hot plugging of the SFP transceiver module will result in an inrush current of no more than 30mA greater than the steady state value.
VccR and VccT may be internally connected within the SFP transceiver module.
8. TD-/+ : These are the differential transmitter inputs. They are AC-coupled, differential lines with 100 Ω differential termination inside the module. The AC coupling is done inside the module and is thus not required on the host board.

6 Package Information

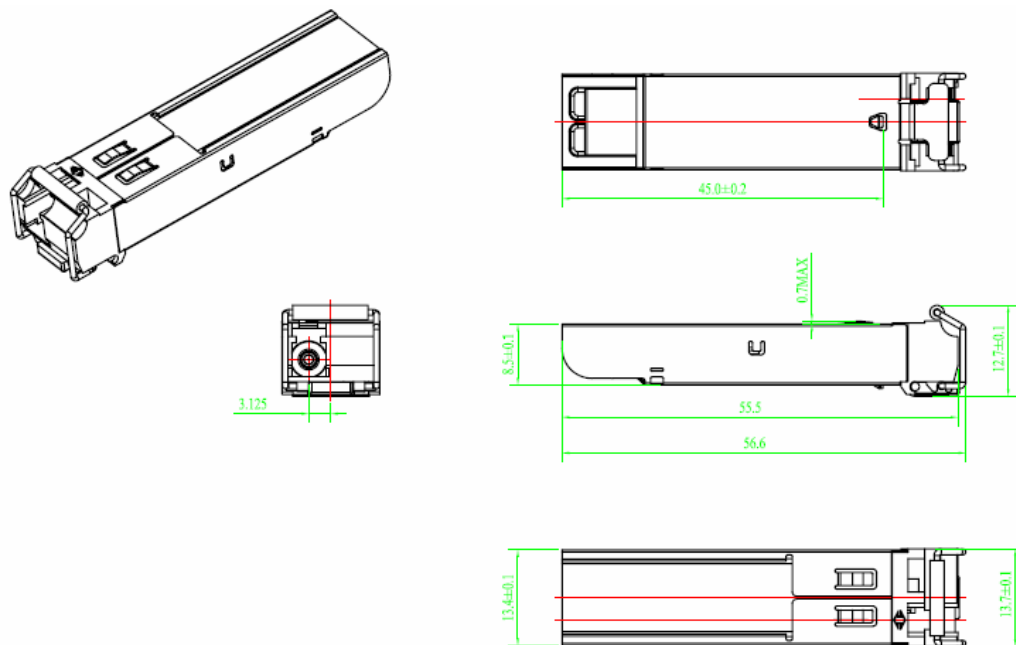

7 Recommended Circuit

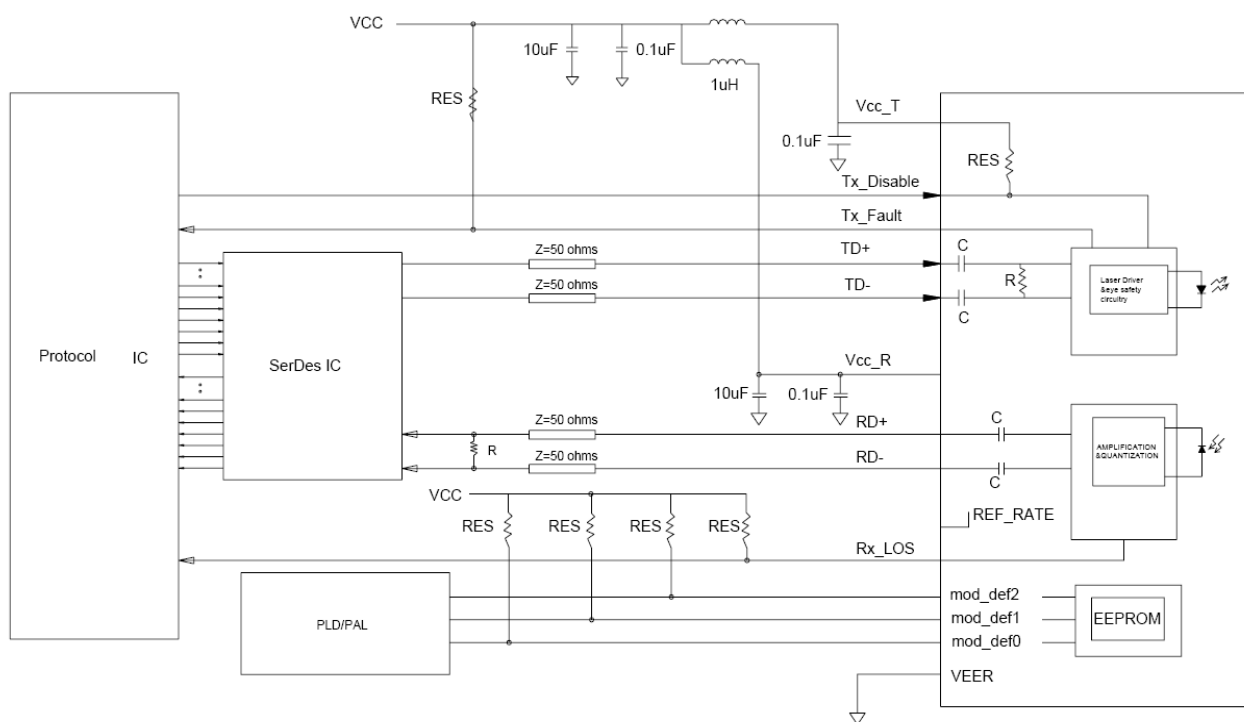

NOTE: 4.7K ohms<RES<10K ohms

8 Pattern Layout of SFP Printed Circuit Board

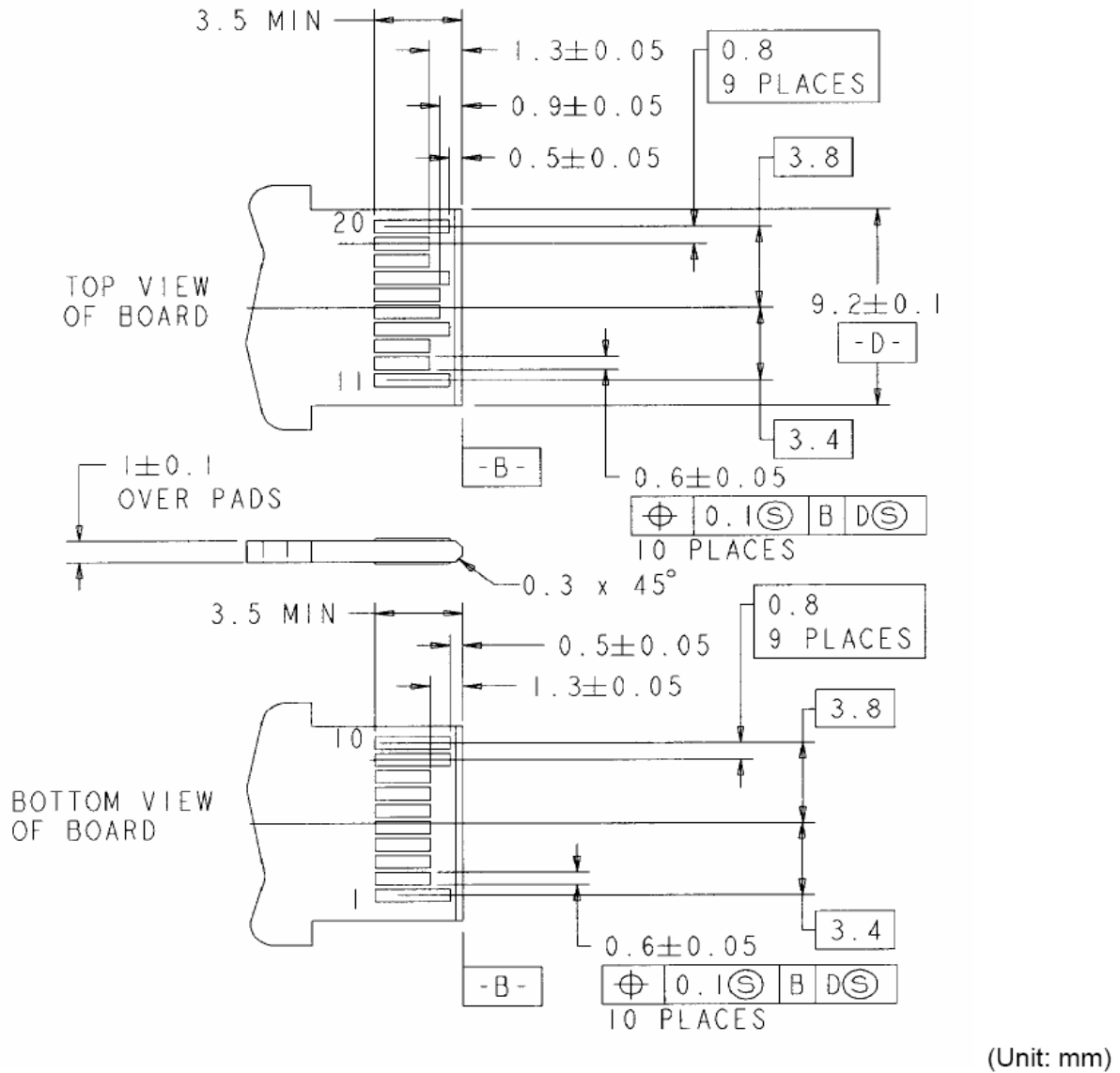

9 Ordering Information

Part Number	Description
EBSP155-3155LXSN	Single LC BIDI SFP, 155Mb/s, 1310nm Tx, 1550nm Rx, 15Km, W/O DDM, -5~75°C

Contact Information:

Address: 2F, Jianxing Building 3; Chaguang Industrial Park; West Shahe Road; Shenzhen; China;
 PC: 518055
 Tel: 86-755-86131609
 Fax: 86-755-26635026