

# Product Specification

**3G SDI Video Optical SFP Receiver Module  
Single Channel  
with PIN Photodiode**

**EP-1RP-3G-H1**

**ePHOTON**

Preliminary

## **EP-1RP-3G-H1**

*3G SDI Video Optical Single Receiver Module  
With PIN Photodiode for SMPTE 292M/424M*

### **1 Features**

- 1.1 Receiver unit with independent PINTIA
- 1.2 SMPTE 297-2006 compatible
- 1.3 Better than -20dBm sensitivity
- 1.4 Supports video pathological patterns for SD-SDI, HD-SDI and 3G-SDI
- 1.5 Diagnose and control via I<sup>2</sup>C interface including:  
Monitoring of receiver optical power, supply voltage  
and module temperature; Alarm reporting; Module ID polling
- 1.7 Industry standard SFP form factor;
- 1.8 Single +3.3V power supply
- 1.9 Operating temperature range: 0°C to 70°C (case)
- 1.10 Hot pluggable
- 1.11 RoHS-6 compliant

### **2 Applications**

- 2.1 3G video application
- 2.2 SMPTE 297-2006 compatible OE interfaces
- 2.3 Broadcast cameras

### **3 General**

The Modules are optical transceiver or transmitter and receiver modules designed to transmit and receive optical and electrical serial digital signals as defined in SMPTE 297-2006. The transceiver or transmitter and receiver are specifically designed for the application with the performance of SDI pathological patterns for SMPTE 259M, 344M, 292M and 424M serial rates.

**4 Functional Block Diagram**

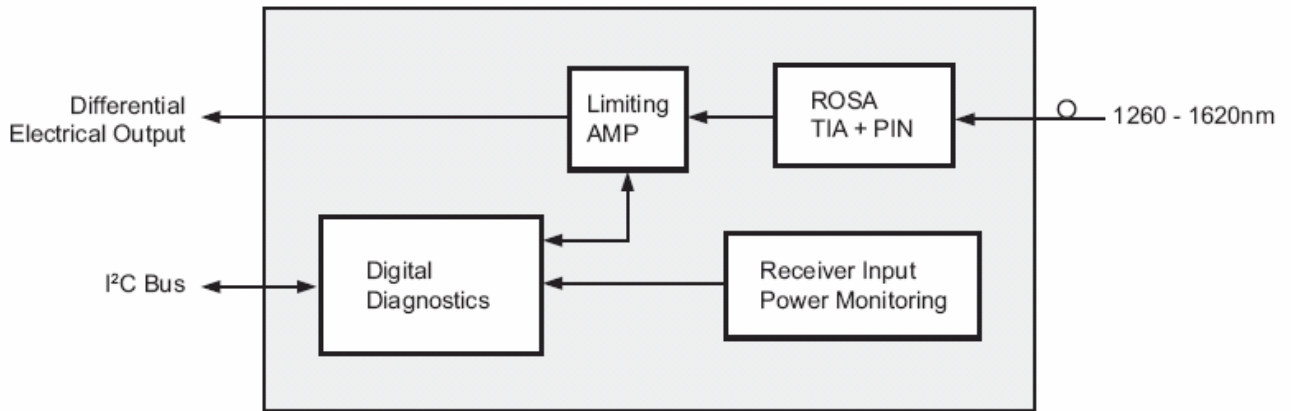

**5 Performance Specifications**

**5.1 Absolute Maximum Ratings**

Parameter	Symbol	Min.	Max.	Unit	Note
Storage Temperature (Non-Operating)	T <sub>stg</sub>	-40	+85	°C	
Case Temperature (Operating)	T <sub>c</sub>	0	+70	°C	1
Power Supply Voltage	V <sub>cc</sub> -V <sub>ee</sub>	-0.5	+3.6	V	
Lead Soldering	T/Sec		260/10	°C/Sec	
Receiver Optical Input Power			5	dBm	
Relative Humidity(non-condensing)		5%	95%	RH	

Note

1. Measured on top side front center of SFP module.

**5.2 Operating Environment**

Parameter	Symbol	Min.	Typ.	Max.	Unit	Note
Power Supply Voltage	V <sub>cc</sub>	+3.1	+3.3	+3.5	V	-
Power Consumption	I <sub>cc</sub>	-	300	550	mW	-
Case Temperature (Operating)	T <sub>c</sub>	0	-	70	°C	-
Data Rate	-	-	-	2.97	Gb/s	-

**5.3 Receiver Specifications**

(Over Operating Case Temperature Range, Vcc = 3.135V to 3.465V)

<b>Electrical Characteristics</b>						
<b>Parameter</b>	<b>Symbol</b>	<b>Min.</b>	<b>Typ.</b>	<b>Max.</b>	<b>Unit</b>	<b>Notes</b>
Differential Data Output Swing	$V_{out,pp}$	600	-	1000	mV	-
Output Resistance	$R_{in}$	42	50	58	ohm	-
<b>Optical Characteristics</b>						
Optical Sensitivity	$P_{sen}$	-	-22	-20	dBm	1,2
Optical Overload	$P_{sat}$	0	-	-	dBm	1,2
Optical Wavelength	$\lambda$	1260	-	1620	nm	
Loss of Signal Asserted		-31	-	-	dBm	
Loss of Signal De-Asserted		-	-	-23	dBm	
Loss of Signal Optical Hysteresis		0.5	-	-	dB	
Maximum Back Reflection		-	-	-27	dB	-

Notes:

- Using 9/125 SMF
- BER=1E-12 against both PRBS and pathological patterns at SMPTE 259M, 292M, 424M rates

## 6 Pin Definitions

### 6.1 Pin Diagram

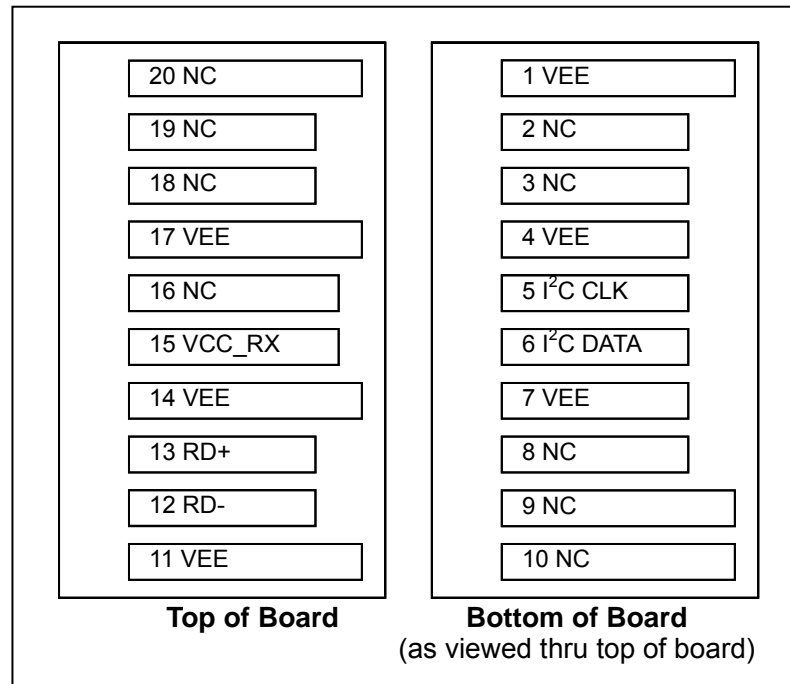

### 6.2 Pin Descriptions

Pin#	Name	Function	Notes
1	VEE	Ground	-
2	NC	Not Connect	-
3	NC	Not Connect	-
4	VEE	Ground	-
5	I2C CLK	I2C Clock	Note 1, 2 wire serial ID interface
6	I2C DATA	I2C, Data	Note 1, 2 wire serial ID interface
7	VEE	Ground	-
8	NC	Not Connect	
9	NC	Not Connect	
10	NC	Not Connect	
11	VEE	Ground	-
12	RD-	Negative Differential Output	AC Coupled Internally
13	RD+	Positive Differential Output	AC Coupled Internally
14	VEE	Ground	-
15	VCC_RX	Power Supply	Note 2, 3.3V 5%
16	NC	Not Connect	Note 2, 3.3V 5%
17	VEE	Ground	-
18	NC	Not Connect	
19	NC	Not Connect	
20	NC	Not Connect	

**Notes:**

1. These are the module definition pins. They should be pulled up with a 4.7K–10K $\Omega$  resistor on the host board. The pull-up voltage shall be VCC.
2. VCC\_RX is the receiver power supplies. It is defined as 3.3V $\pm$ 5% at the SFP connector pin. Maximum supply current is 150mA. Recommended host board power supply filtering is shown below. Inductors with DC resistance of less than 1 $\Omega$  should be used in order to maintain the required voltage at the SFP input pin with 3.3V supply voltage. When the recommended supply filtering network is used, hot plugging of the SFP transceiver module will result in an inrush current of no more than 30 mA greater than the steady state value.

**6.3 Optical Connector**

An LC connector with PC/UPC is required for each port.

## 7. Serial interface memory map

Module identification and diagnostic information is accessible through the address map shown in the following tables .

### 7.1 EEPROM serial ID memory contents (A0h)

Addr	Hex	ASCII	Description	Addr	Hex	ASCII	Description	Addr	Hex	ASCII	Description
0	84		Single Receiver	32	20		Vendor name	64	00		
1	04		SFP function is defined by serial ID only	33	20			65	03		
2	07		LC connector	34	20			66	00		BR, Max
3	41		SMPTE259M/344M/292M/424M and 297M	35	20			67	00		BR, Min.
4	00		Reserved(SFP MSA does not specify SMPTE compliance codes)	36	XX		Reserved	68	XX		Vendor Serial number
5	00			37	00		Vendor OUI	69	XX		
6	00			38	00			70	XX		
7	00			39	00		Vendor part number	71	XX		
8	00			40	45	E		72	XX		
9	00			41	50	P		73	XX		
10	00			42	2D	-		74	XX		
11	03		NRZ	43	31	1	75	XX			
12	1E	3G	BR in 100Mbps	44	52	R	76	XX			
13	00		Reserved	45	50	P	77	XX			
14	00		Length(9u)*Km	46	2D	-	78	XX			
15	00		Length(9u)*100m	47	33	3	79	XX			
16	00		Length(50u)*10m	48	47	G	80	XX			
17	00		Length(62.5u)*10m	49	2D	-	81	XX			
18	00		Length(Copper)	50	48	H	82	XX			
19	XX		Reserved	51	31	1	83	XX			
20	65	E	Vendor name	52	20			84	XX		Vendor data code: Year
21	50	P		53	20			85	XX		
22	48	H		54	20			86	XX		Vendor data code: Month
23	4F	O		55	20			87	XX		
24	54	T		56	00			88	XX		Vendor data code: Day
25	4F	O		57	00	.		89	XX		
26	4E	N		58	00			90	20		Blank
27	20			59	00		Vendor PN reversion preliminary	91	20		
28	20			60	20		NA	92	28		
29	20			61	20		NA	93	90		Enhanced alarm/warning flags
30	20		62	00		Reserved	94	XX		Reserved	
31	20		63	XX		CC_BASE(0-62)	95	XX		CC_EXT(64-94)	

96-127: 00, Vendor specific

128-255: 00, Reserved

XX: denotes hex values which varies from module to module

**7.2 EEPROM serial ID memory contents (A2h)**
**7.2.1 Alarm and Warning Thresholds, OM Output Calibration ID Fields**

Addr. (DEC)	# Bytes	Name	Value
00-01	2	Temp high alarm	+120°C
02-03	2	Temp low alarm	-13°C
04-05	2	Temp high warning	+110°C
06-07	2	Temp low warning	-8°C
08-09	2	Supply voltage high alarm	+3.6V
10-11	2	Supply voltage low alarm	+3.0V
12-13	2	Supply voltage high warning	+3.47V
14-15	2	Supply voltage low warning	+3.14V
16-31	16	NA	
32-33	2	Rx Power High Alarm	1.5dBm
34-35	2	Rx Power Low Alarm	-25dBm
36-37	2	Rx Power High Warning	0dBm
38-39	2	Rx Power Low Warning	-23dBm
40-94	59	Reserved	
95	1	Check sum	Byte 95 contains the low order 8 bits of the sum of bytes 0-94

**7.2.2 A/D Values and Status Bits**

Addr. (DEC)	Bit	Name	Description
96	All	Temperature MSB	Internally measured module temperature, see table 7.2.3
97	All	Temperature LSB	
98	All	Vcc MSB	Internal measured supply voltage, see table 7.2.3
99	All	Vcc LSB	
100-103	All	NA	
104	All	Rx Power MSB	Internally Measured Rx Power
105	All	Rx Power LSB	Internally Measured Rx Power
106-109	All	Reserved	
<b>Optional status/control bits</b>			
110	7-3		Reserved
110	2	N/A	
110	1	LOS	Indicates Rx_LOS state
110	0	Data_Ready	
111	7	Temp_Update	Goes to high after a temperature update
	6	Vcc_Update	Goes to high after a Vcc update
	5	Mon 1 Update	Goes to high after a Tx bias current update
	4	Mon 2 Update	Goes to high after a TX power update
	3	Mon 3 Update	Goes to high after a Rx input power update
	2-0	Reserved	

### 7.2.3 Receiver only

A2h address	Parameter	Calibration	Accuracy	Range
96-97	Temperature	Internal	+/- 3°C	Note 1
98-99	Vcc	Internal	+/- 3%	3.135 to 3.465
104-105	Rx power	External	+/- 3dB	-23 to 0dBm

**Notes:**

1. Junction temperature of temperature sensing device

### 7.2.4 Alarm and Warning Flags

Addr. (DEC)	Bit	Name	Description
112	7	Temp high alarm	Set when internal temperature exceeds high alarm level
	6	Temp low alarm	Set when internal temperature below low alarm level
	5	Vcc high alarm	Set when internal supply voltage exceeds high alarm level
	4	Vcc low alarm	Set when internal supply voltage below low alarm level
	3-0	NA	
113	7	Rx power high alarm	Set when the monitored Rx power exceeds the Rx power high alarm threshold
	6	Rx power low alarm	Set when the monitored Rx power goes below the Rx power low alarm threshold
	5-0	Reserved	
114-115	All	Reserved	
116	7	Temp high warning	Set when internal temperature exceeds high warning level
	6	Temp low warning	Set when internal temperature below low warning level
	5	Vcc high warning	Set when internal supply voltage exceeds high warning level
	4	Vcc low warning	Set when internal supply voltage below low warning level
	3-0	N/A	
117	7	Rx Power High Warning	Set when the monitored Rx power exceeds the Rx power high warning threshold
	6	Rx Power Low Warning	Set when the monitored Rx power goes below the Rx power low alarm threshold
	5-0	Reserved	
118-119	all	Reserved	

### 7.2.5 Vendor Specific Memory Addresses

Addr. (DEC)	# Bytes	Name	Description
120-127	8	Vendor specific	Vendor specific

### 7.2.6 User EEPROM

Addr. (DEC)	# Bytes	Name	Description
128-247	120	Vendor Writable Area	Vendor writable EEPROM
248-255	8	Vendor specific	Vendor specific control functions

### 8 Package Information

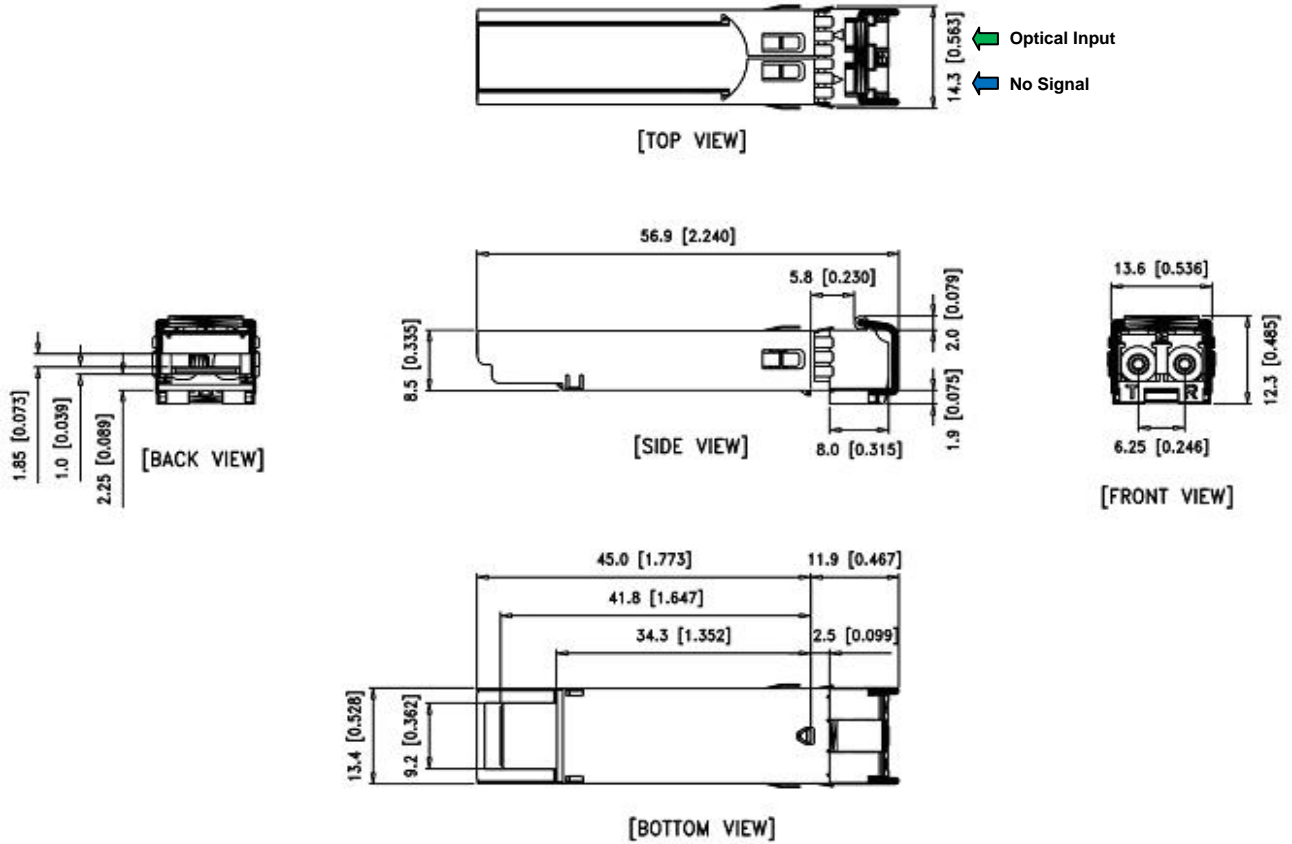

### 9 Recommended Circuit

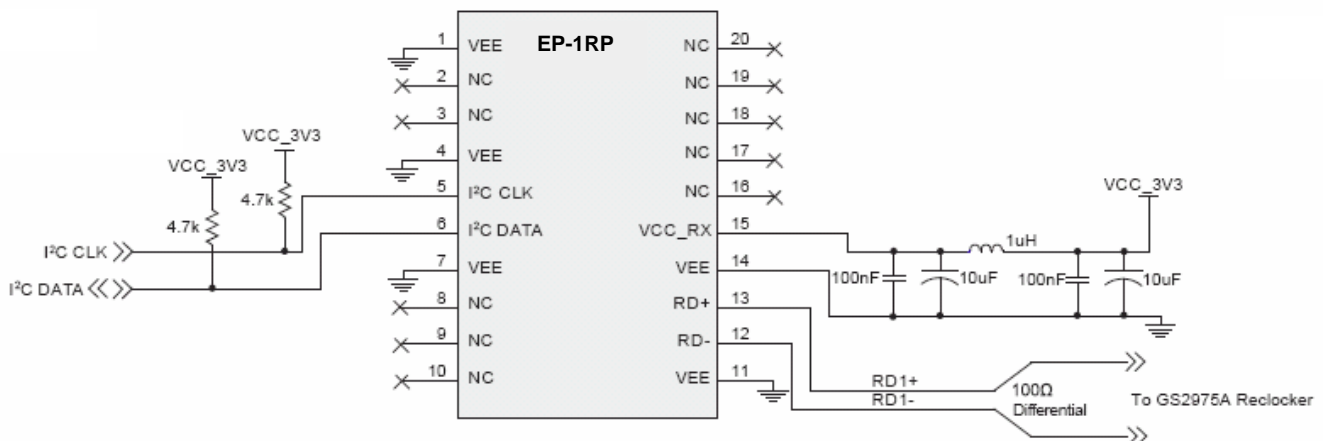

**10 Pattern Layout of SFP Printed Circuit Board**

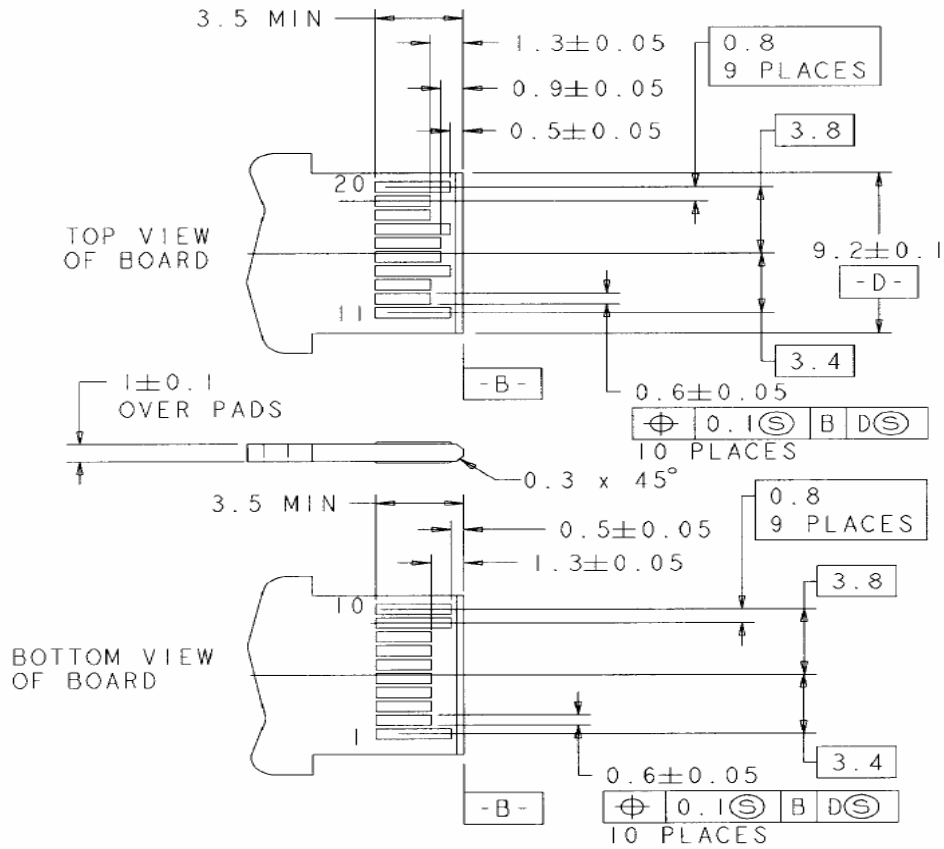

(Unit: mm)

**11 Recommended PCB Layout**

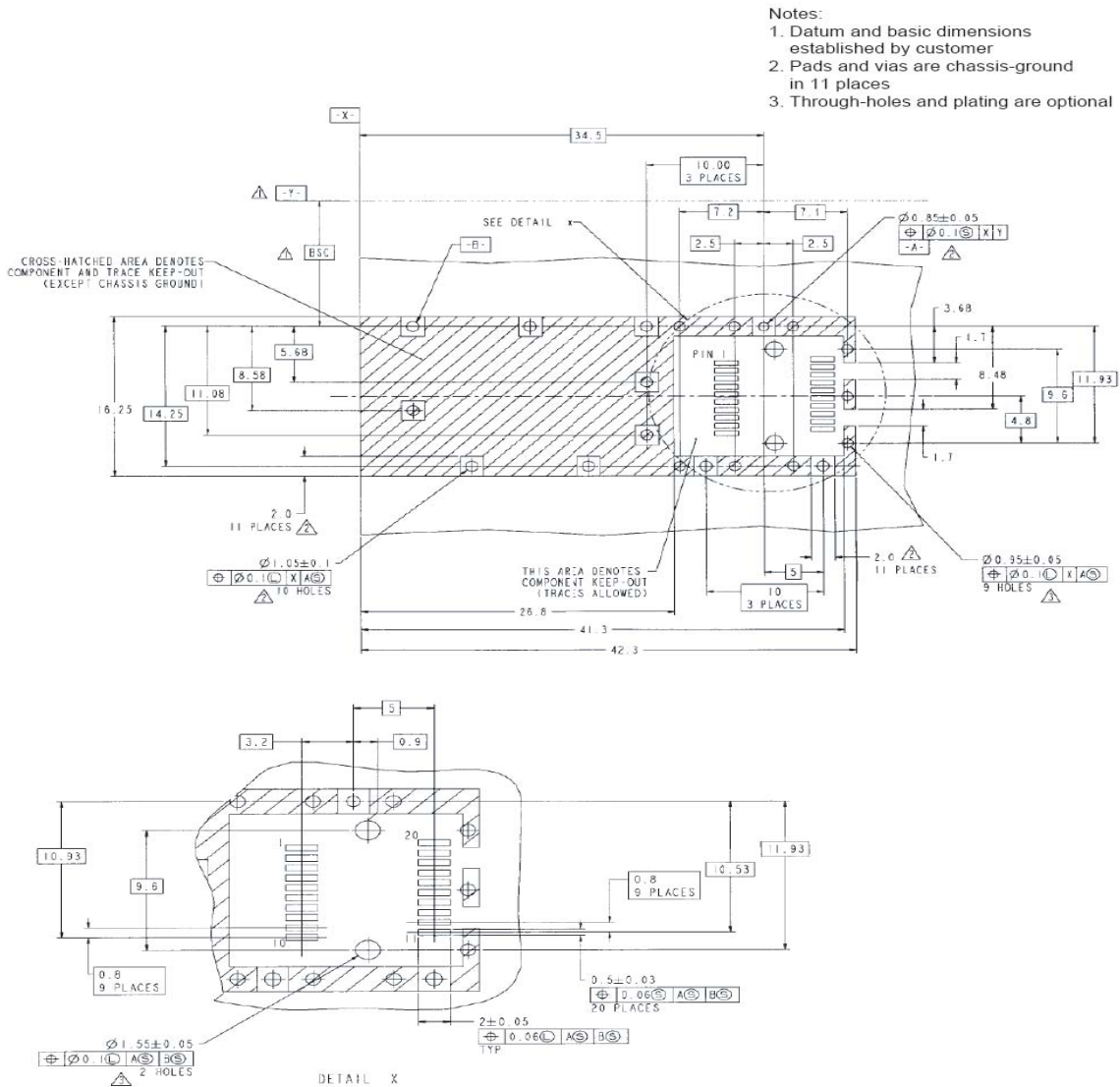

**12 Ordering Information**

Part Number	Brief Description
EP-1RP-3G-H1	Video Single Receiver, 3G, DDM, 0~70°C

**Contact Information:**

Address: 2F, Jianxing Building 3; Chaguang Industrial Park; West Shahe Road; Shenzhen; China;  
 PC: 518055  
 Tel: 86-755-86131609  
 Fax: 86-755-26635026