

# Product Specification

*6.25Gb/S 2Km SFP+ Optical Transceiver Module*

**ESFP6G-31ARS**

**ePHOTON**

Preliminary

### ESFP6G-31ARS

#### 6.25Gb/s 2Km SFP+ Optical Transceiver Module

#### 1 Features

- 1.1 6.25Gb/s serial optical interface over 2km single mode fiber
- 1.2 Electrical interface compliant to SFF-8431 specifications for enhanced 8.5 and 10 Gigabit small form factor pluggable model "SFP+"
- 1.3 1310nm FP transmitter and PIN receiver
- 1.4 2-wire interface for management specification compliant with SFF 8472 digital diagnostic monitoring interface for optical transceivers
- 1.5 Operating case temperature: 0 to 70°C
- 1.6 All-metal housing for superior EMI performance
- 1.7 Low power consumption
- 1.8 Advanced firmware allow customer system encryption information to be stored in transceiver
- 1.9 RoHS compliant



#### 2 Applications

- 2.1 High speed storage area networks
- 2.2 Computer cluster cross-connect
- 2.3 Custom high speed data pipes

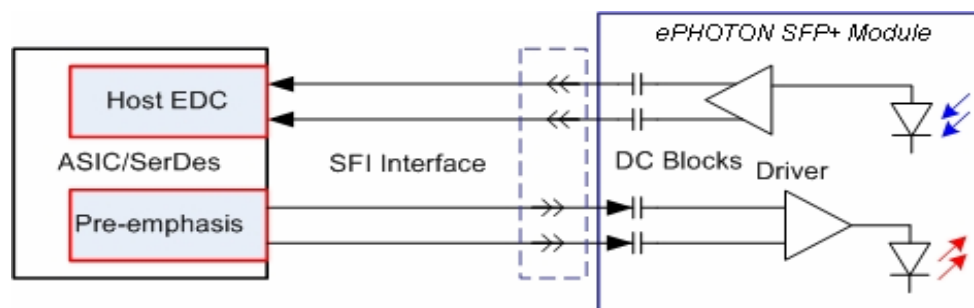

Application in System

### 3 General Description

This 1310 nm FP 6.25Gigabit SFP+ transceiver is designed to transmit and receive optical data over single mode optical fiber for link length 2km.

The SFP+ 6.25G module electrical interface is compliant to SFI electrical specifications. The transmitter input and receiver output impedance is 100 Ohms differential. Data lines are internally AC coupled. The module provides differential termination and reduce differential to common mode conversion for quality signal termination and low EMI. SFI typically operates over 200 mm of improved FR4 material or up to about 150mm of standard FR4 with one connector.

The transmitter converts 6.25Gbit/s serial PECL or CML electrical data into serial optical data. An open collector compatible Transmit Disable (Tx\_Dis) is provided. A logic "1," or no connection on this pin will disable the laser from transmitting. A logic "0" on this pin provides normal operation. The transmitter has an internal automatic power control loop (APC) to ensure constant optical power output across supply voltage and temperature variations. An open collector compatible Transmit Fault (Tx\_Fault) is provided. TX\_Fault is a module output contacts that when high, indicates that the module transmitter has detected a fault condition related to laser operation or safety. The TX\_Fault output contact is an open drain/collector and shall be pulled up to the Vcc\_Host in the host with a resistor in the range 4.7-10 kΩ. TX\_Disable is a module input contact. When TX\_Disable is asserted high or left open, the SFP+ module transmitter output shall be turned off. This contact shall be pulled up to VccT with a 4.7 kΩ to 10 kΩ resistor.

The receiver converts 6.25Gbit/s serial optical data into serial PECL/CML electrical data. An open collector compatible Loss of Signal is provided. Rx\_LOS when high indicates an optical signal level below that specified in the relevant standard. The Rx\_LOS contact is an open drain/collector output and shall be pulled up to Vcc\_Host in the host with a resistor in the range 4.7-10 kΩ, or with an active termination. Power supply filtering is recommended for both the transmitter and receiver. The Rx\_LOS signal is intended as a preliminary indication to the system in which the SFP+ is installed that the received signal strength is below the specified range. Such an indication typically points to non-installed cables, broken cables, or a disabled, failing or a powered off transmitter at the far end of the cable.

### 4 Transceiver Block Diagram

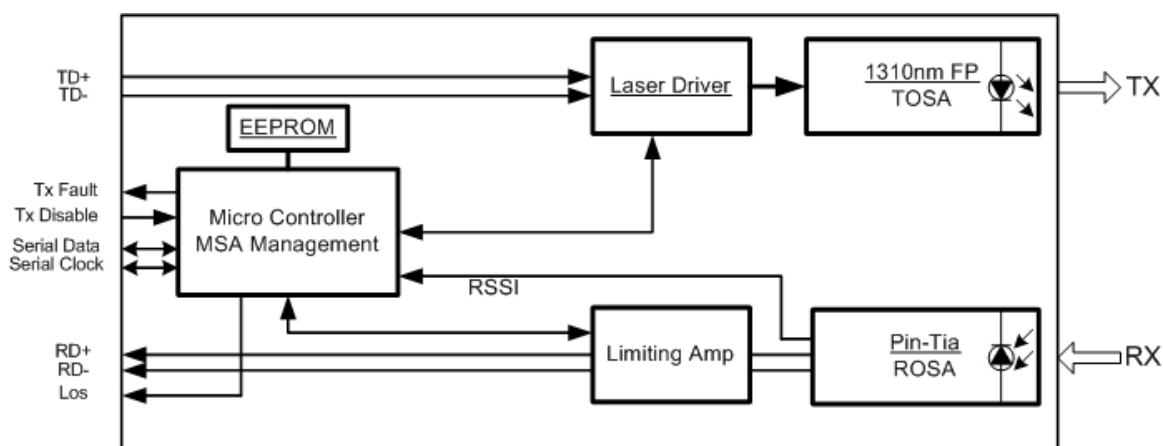

### 5 Pin Assignment and pin description

The SFP+ modules are hot-pluggable. Hot pluggable refers to plugging in or unplugging a module while the host board is powered. The SFP+ host connector is a 0.8 mm pitch 20 position right angle improved connector specified by SFF-8083, or stacked connector with equivalent with equivalent electrical performance. Host PCB contact assignment is shown in Figure of “Module interface host” and contact definitions are given in table of “SFP+ module pin definition”. SFP+ module contacts mates with the host in the order of ground, power, followed by signal as illustrated by figure of “Module contact assignment” and the contact sequence order listed in table of “SFP+ module pin definition”.

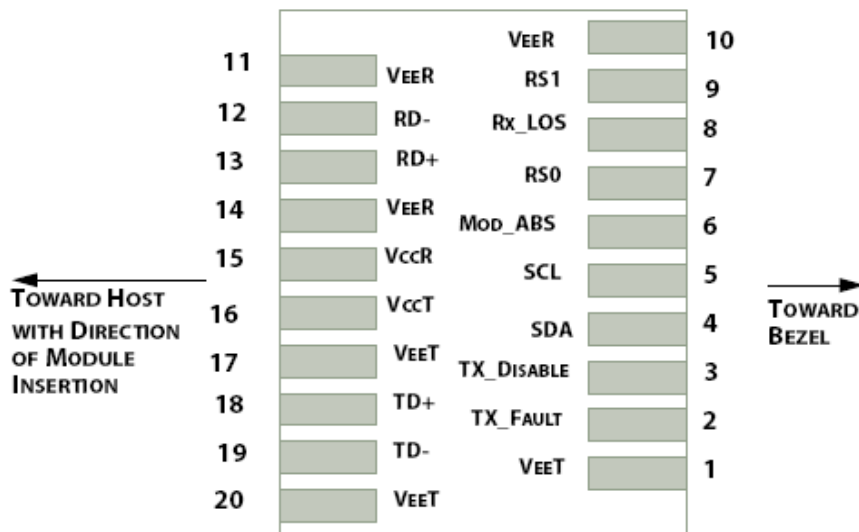

Module Interface to Host

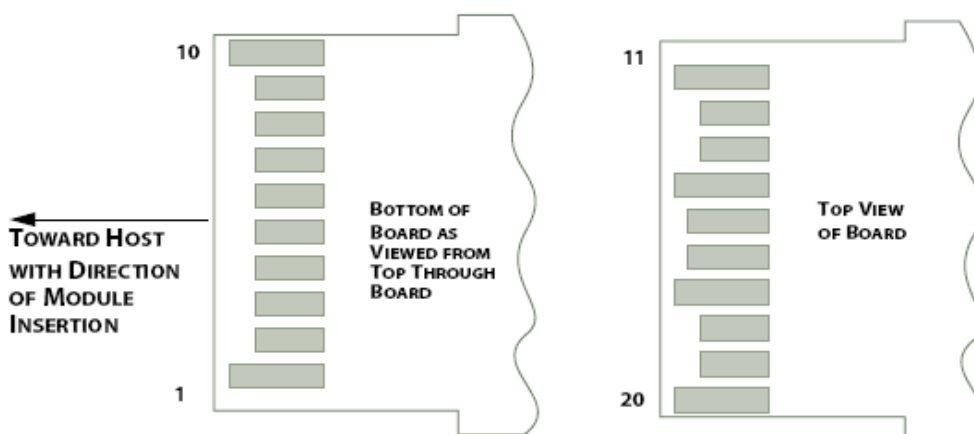

Module Contact Assignment

**SFP+ Module PIN Definition**

PIN	Logic	Symbol	Name / Description	Note
1		VeeT	Module Transmitter Ground	1
2	LVTTL-O	TX_Fault	Module Transmitter Fault	
3	LVTTL-I	TX_Dis	Transmitter Disable; Turns off transmitter laser output	
4	LVTTL-I/O	SDA	2-Wire Serial Interface Data Line	2
5	LVTTL-I	SCL	2-Wire Serial Interface Clock	2
6		MOD_DEF0	Module Definition, Grounded in the module	
7	LVTTL-I	RS0	Receiver Rate Select	
8	LVTTL-O	RX_LOS	Receiver Loss of Signal Indication Active High	
9	LVTTL-I	RS1	Transmitter Rate Select	
10		VeeR	Module Receiver Ground	1
11		VeeR	Module Receiver Ground	1
12	CML-O	RD-	Receiver Inverted Data Output	
13	CML-O	RD+	Receiver Data Output	
14		VeeR	Module Receiver Ground	1
15		VccR	Module Receiver 3.3 V Supply	
16		VccT	Module Receiver 3.3 V Supply	
17		VeeT	Module Transmitter Ground	1
18	CML-I	TD+	Transmitter Non-Inverted Data Input	
19	CML-I	TD-	Transmitter Inverted Data Input	
20		VeeT	Module Transmitter Ground	1

**Note:**

1. Module ground pins GND are isolated from the module case
2. Shall be pulled up with 4.7K-10Kohms to a voltage between 3.15V and 3.45V on the host board.

6 Proposed application schematics

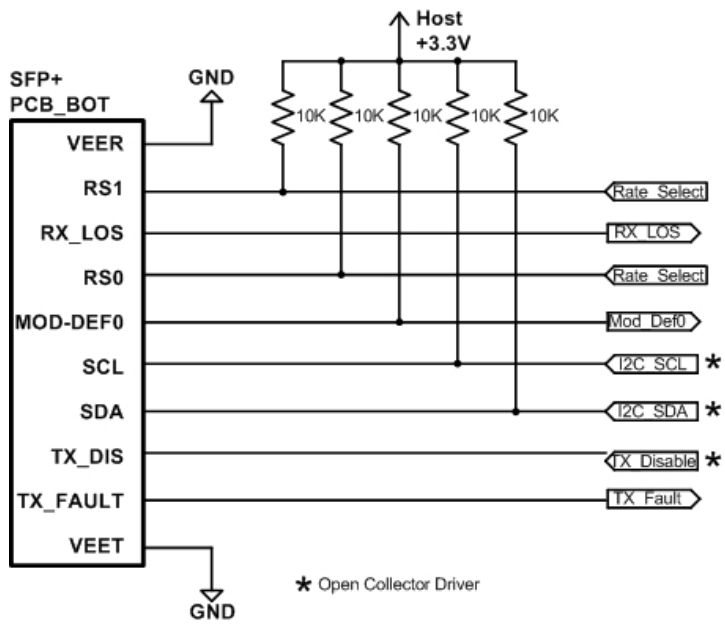
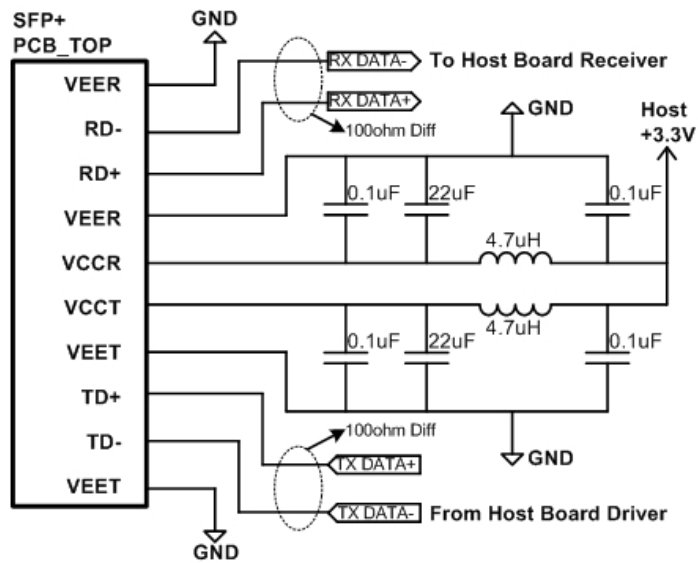

## 7 Performance Specifications

### 7.1 Absolute Maximum Ratings

These values represent the damage threshold of the module. Stress in excess of any of the individual Absolute Maximum Ratings can cause immediate catastrophic damage to the module even if all other parameters are within Recommended Operating Conditions.

Parameters	Symbol	Min.	Max.	Unit
Power Supply Voltage	$V_{CC}$	0	3.6	V
Storage Temperature	$T_c$	-40	85	°C
Operating Case Temperature	$T_c$	0	70	°C
Relative Humidity	RH	5	95	%
RX Input Average Power	$P_{max}$	-	0	dBm

### 7.2 Recommended Conditions and Supply Requirement

Parameters	Symbol	Min.	Typical	Max	Unit
Power Supply Voltage	$V_{CC}$	3.135	3.3	3.465	V
Power Supply Current	$I_{CC}$			300	mA
Operating Case Temperature	$T_c$	0	25	70	°C

### 7.3 Optical characteristics

The following optical characteristics are defined over the Recommended Operating Environment unless otherwise specified.

Parameters	Unit	Values
<b>Operating Reach</b>	<b>m</b>	<b>Up to 2K</b>
<b>Transmitter</b>		
Center wavelength (range)	nm	1260 -1360
Launched power		
– maximum (Average)	dBm	0.5
– minimum (Average)	dBm	-8.2
– OMA(min)	dBm	-5.2
– OMA-TDP (min)	dBm	-6.2
Transmitter and dispersion penalty (max)	dB	3.2
Average launch power of OFF transmitter (max)	dBm	-30
Extinction ratio (min)	dB	3.5
RIN12 OMA (max)	dB/Hz	-128
Optical Return Loss Tolerance (min)	dB	12
<b>Receiver</b>		
Center wavelength (range)	nm	1260-1360
Receive overload (max) in average power(note 1)	dBm	0.5
Receive sensitivity (min) in average power(note 1)	dBm	-14.4
Receiver sensitivity (max) in OMA (note 2)	dBm	-12.6
Receiver Reflectance (max)	dB	-12
Stressed receiver sensitivity (max) in OMA(note 2)	dBm	-10.3

Vertical eye closure penalty (min)(note 3)	dB	2.2
Los Assert(min)	dBm	-30
Los Dessert(max)	dBm	-12
Los Hysteresis(min)	dB	0.5
Stressed eye jitter (min)(note 2)	UIp-p	0.3
Receive electrical 3dB upper cutoff frequency (max)	GHz	12.3
Receiver power (damage, Max)	dBm	1.5

**Notes:**

1. Average optical power shall be measured using the methods specified in TIA/EIA-455-95.
2. Receiver sensitivity is informative. Stressed receiver sensitivity shall be measured with conformance test signal for BER =  $1 \times 10^{-12}$ .
3. Vertical eye closure penalty and stressed eye jitter are the test conditions for measuring stressed receiver sensitivity. They are not the required characteristic of the receiver.
4. Power budget is defined as the different between the Rx sensitivity and the Tx output power of the interface.
5. Path penalty is intended as the power penalty of the interface between back-to-back and the maximum applied dispersion.

#### 7.4 Digital diagnostic functions

The following digital diagnostic characteristics are defined over the Recommended Operating Environment unless otherwise specified. It is compliant to SFF8472 Rev10.2 with internal calibration mode. For external calibration mode please contact our sales staff.

Parameter	Symbol	Min.	Max	Unit	Notes
Temperature monitor absolute error	DMI_Temp	-3	3	degC	Over operating temp
Laser power monitor absolute error	DMI_TX	-3	3	dB	
RX power monitor absolute error	DMI_RX	-3	3	dB	-1dBm to -15dBm range
Supply voltage monitor absolute error	DMI_VCC	-0.08	0.08	V	Full operating range
Bias current monitor	DMI_Ibias	-10%	10%	mA	

#### 7.5 Electrical characteristics

The following electrical characteristics are defined over the Recommended Operating Environment unless otherwise specified.

Parameter	Symbol	Min.	Typical	Max	Unit	Notes
Data Rate		-	6.25	-	Gbps	
Power Consumption		-	800	1000	mW	
Transmitter						
Single Ended Output Voltage Tolerance		-0.3	-	4	V	
Common mode voltage tolerance		15	-	-	mV	
Tx Input Diff Voltage	VI	90		350	mV	
Tx Fault	VoL	-0.3		0.4	V	At 0.7mA

Data Dependent Input Jitter	DDJ			0.1	UI	
Data Input Total Jitter	TJ			0.28	UI	
<b>Receiver</b>						
Single Ended Output Voltage Tolerance		-0.3	-	4	V	
Rx Output Diff Voltage	Vo	150		425	mV	
Rx Output Rise and Fall Time	Tr/Tf	50			ps	20% to 80%
Total Jitter	TJ			0.7	UI	
Deterministic Jitter	DJ			0.42	UI	

### 7.6 Control and status I/O timing characteristics

Timing characteristics of control and status I/O are included in Table 8, which is also defined in SFF-8431.

Parameter	Symbol	Min	Max	Unit	Condition
TX Disable Assert Time	t_off		10	μs	Time from rising edge of TX Disable to when the optical output falls below 10% of nominal
TX Disable Negate Time	t_on		1	ms	Time from falling edge of TX Disable to when the modulated optical output rises above 90% of nominal
Time to initialize, including reset of TX_Fault	t_init		300	ms	From power on or negation of TX Fault using TX Disable
TX Fault Assert Time	t_fault		100	μs	Time from fault to TX fault on.
TX Disable to reset	t_reset	10		μs	Time TX Disable must be held high to reset TX_fault
LOS Assert Time	t_loss_on		100	μs	Time from LOS state to RX LOS assert
LOS Deassert Time	t_loss_off		100	μs	Time from non-LOS state to RX LOS deassert
Rate-Select Change Time	t_ratesel		10	μs	Time from rising or falling edge of Rate Select input until receiver bandwidth is in conformance with appropriate specification.
Serial ID Clock Rate	f_serial_clock		100	kHz	

### 8 Package Information

Compliant to SFF-8432 rev 5.0. the improved Pluggable form factor specifications

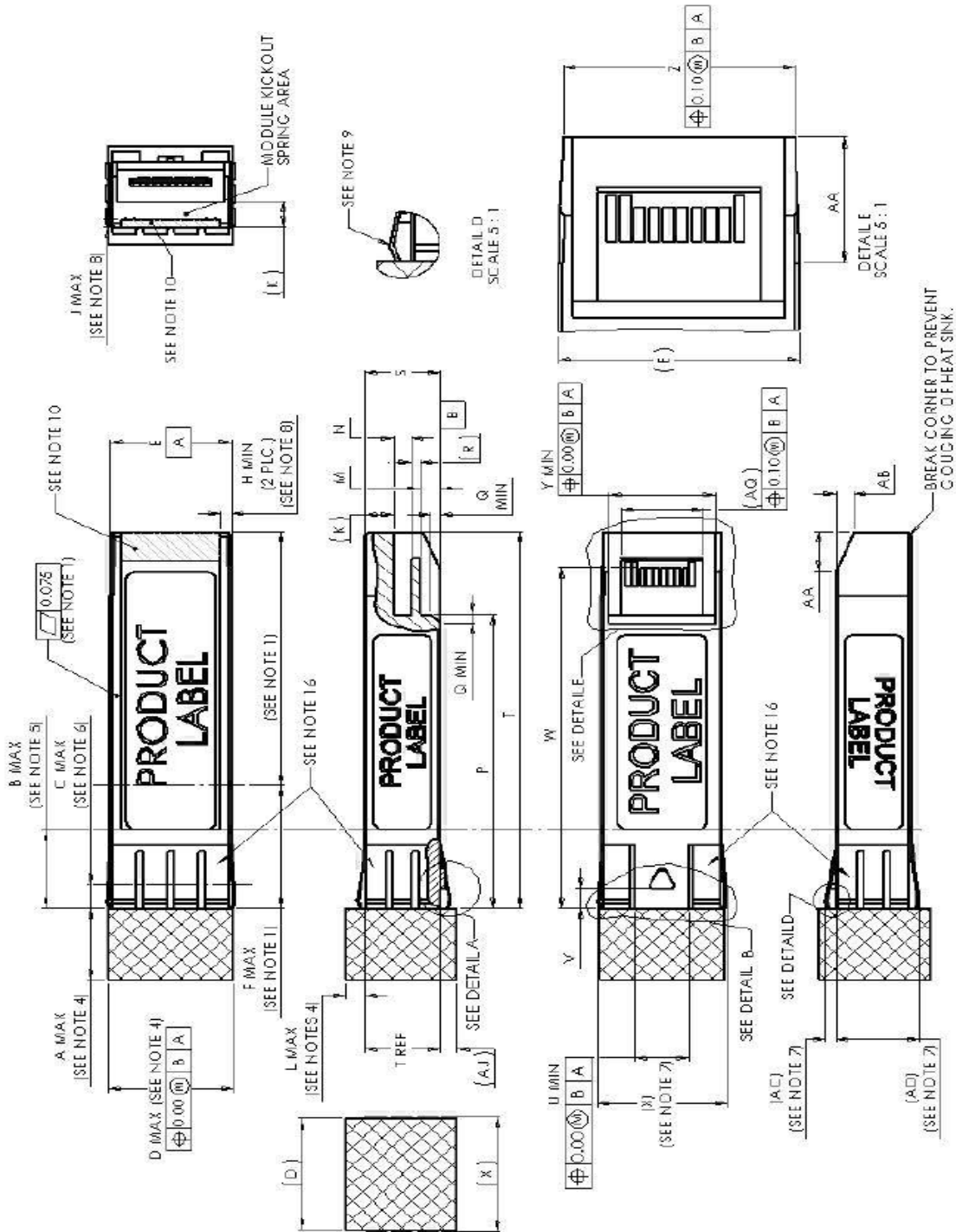

Designator	Dimension (mm)	Tolerance (mm)	Comments
A	10.00	Recommended Maximum	Module length extending outside of cage, see Note 4. Other lengths are application specific.
B	10.00	Maximum	Designated EMI ground spring area, see Note 5
C	3.00	Maximum	EMI spring/Cage Contact Point, see Note 6
D	14.00	Maximum	Module width extending outside of cage, see Note 4
E	13.55	±0.25	Module width
F	15.50	Maximum	Distance to front end of optional heat sink area, see Note 1
H	1.25	Minimum	Top slot distance from edge, see note 8
J	1.00	Maximum	Top slot depth, see note 8
K	3.25	Reference	Height of module kick-out spring area
L	2.10	Maximum	Module top height extending outside of cage see Note 4
M	2.25	±0.10	Distance from bottom of Module to printed circuit board
N	2.00	±0.25	Distance from rear shoulder to printed circuit board
P	37.10	±0.30	Distance from positive stop to bottom opening of Module and beginning of bottom rear relief

## 9 ESD

This transceiver is specified as ESD threshold 2kV for all electrical input pins, tested per MIL-STD-883, Method 3015.4/JESD22-A114-A (HBM). However, normal ESD precautions are still required during the handling of this module. This transceiver is shipped in ESD protective packaging. It should be removed from the packaging and handled only in an ESD protected environment

## 10 Laser Safety

This is a Class 1 Laser Product according to IEC 60825-1:1993+A1:1997+A2:2001. This product complies with 21 CFR 1040.10 and 1040.11 except for deviations pursuant to Laser Notice No. 50, dated (July 26, 2001)

## 11 Ordering Information

Part Number	Product Brief Description
ESFP6G-31ARS	6.25Gb/s, 2Km, 1310nm FP LD, SFP+, 0~70°C

### Contact Information:

Address: 2F, Jianxing Building 3; Chaguang Industrial Park; West Shahe Road; Shenzhen; China;  
PC: 518055  
Tel: 86-755-86131609  
Fax: 86-755-26635026