

Product Specification

*SDH/SONET STM-1/OC-3 155Mbps 40Km
1x9 Receptacle Duplex SC Transceiver*

ETR9155-31LR1A

ePHOTON

Ver A

ETR9155-31LR1A SDH/SONET STM-1/OC-3 155Mbps 40Km 1X9 Duplex SC Receptacle Transceiver

1 Features

- 1.1 Transceiver unit with independent
1310nm FP Laser diode transmitter
InGaAs PIN photodiode receiver
- 1.2 Duplex SC receptacle optical interface
- 1.3 Single +3.3V power supply
- 1.4 Standard 1x9 package
- 1.5 LVPECL compatible data input/output interface
- 1.6 -40°C to 85°C operating temperature range optional
- 1.7 Compliant with ITU-T G.957



2 Applications

- 2.1 SDH STM-4 S4.1
- 2.2 SONET
- 2.3 ATM

3 General

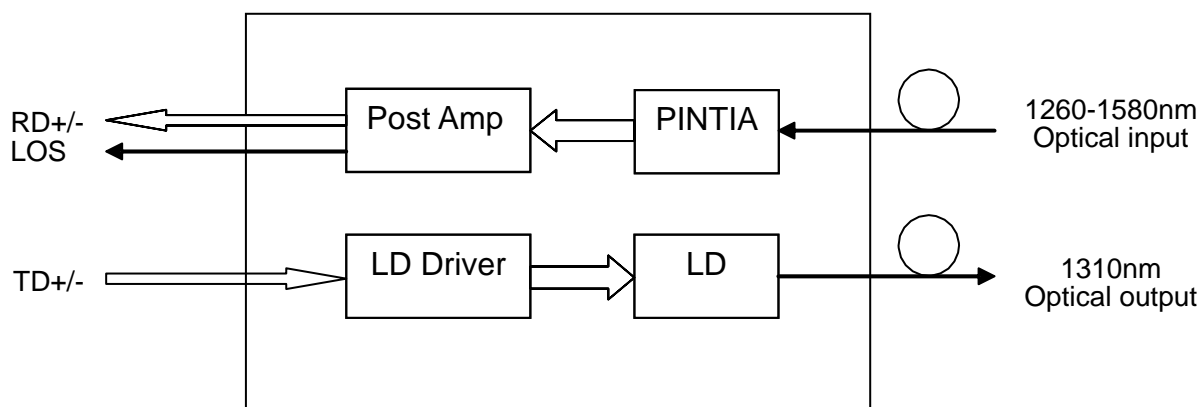

3.1 Transmitter Section

Transmitter is designed for single mode fiber and operates at a nominal wavelength of 1310nm. The transmitter module uses a FP laser diode and full IEC825 and CDRH class 1 eye safety. It contains APC function, temperature compensation circuit, PECL data inputs interface.

3.2 Receiver Section

The receiver section uses a hermetic packaged front end receiver (InGaAs PIN and preamplifier). The post amplifier is ac coupled to preamplifier through a capacitor and a low pass filter. The capacitor and LPF are enough to pass the signal from 5Mb/s to 155Mb/s without significant distortion or performance penalty. The

LPF limits the preamplifier bandwidth to improve receiver sensitivity. As the input optical is decreased, LOS will switch from low to high. As the input optical power is increased from very low levels, LOS will switch back from high to low.

4 Performance Specifications

4.1 Absolute Maximum Ratings

Parameter	Symbol	Min.	Max.	Unit
Storage Temperature (Non-Operating)	Tstg	-40	+85	°C
Relative Humidity	RH	0	95	%
Lead Solder Temperature/Duration	-	-	260/10	°C/S
Input/Output Voltage	-	GND	Vcc	V
Power Supply Voltage	Vcc-Vee	-0.5	+4.5	V

4.2 Operating Environment

Parameter	Symbol	Min.	Typ.	Max.	Unit	Note
Power Supply Voltage	V _{CC}	+3.1	+3.3	+3.5	V	-
Case Temperature (Operating)	T _C	-40	-	85	°C	-
Data Rate	-	-	155	-	Mb/s	-
Supply Current	I _{CC}	-	-	250	mA	-
Transmitter Differential Input Voltage	V _D	300	-	1860	mV	-
Common mode Input Voltage	V _{com} -V _{CC}	-1.38	-	-0.47	V	-
LVPECL Output Voltage-Low	V _{OL} -V _{CC}	-1.810	-	-1.620	V	1
LVPECL Output Voltage-High	V _{OH} -V _{CC}	-1.025	-	-0.880	V	1

4.3 Transmitter E-O characteristics

Parameter	Symbol	Min.	Typ.	Max.	Unit	Note
Center Wavelength	λ	1263	1310	1360	nm	-
Spectral Width (RMS)	$\Delta \lambda$	-	-	3	nm	-
Average Optical Output Power	P _o	-5	-	0	dBm	2
Extinction Ratio	E _r	9	-	-	dB	-
Output Eye Diagram	Compliant with ITU recommendation G.957 STM-1/OC-3					

4.4 Receiver O-E Characteristics

Parameter	Symbol	Min.	Typ.	Max.	Unit	Note
Operate Wavelength	-	1260	-	1580	nm	-
Sensitivity	Sen	-	-36	-28	dBm	3
Saturation	P _{sal}	-8	-	-	dBm	3
LOS Asserted	-	-52	-	-	dBm	High Level: Alarm
LOS De-Asserted	-	-	-	-36	dBm	
LOS Hysteresis	-	0.5	-	6	dB	

Notes:

1. Terminated with 50 ohms to Vcc-2V;
2. Minimum output optical level is at end of life;
3. Sensitivity and saturation levels for a 2²³-1 PRBS and BER better than or equal to 10e-10.

5 Pin Definitions

5.1 Pin Diagram

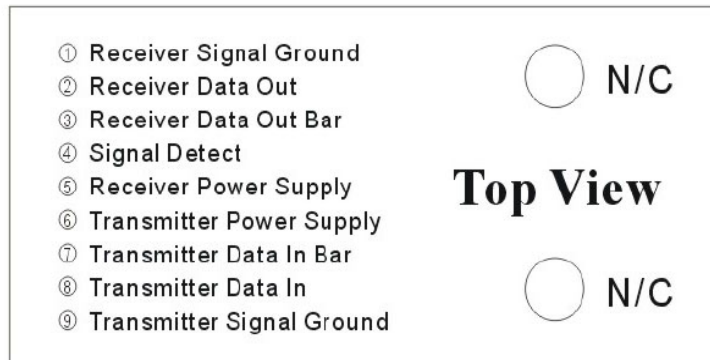

5.2 Pin Descriptions

Pin#	Name	Function
1	Vee	Negative power of receiver section, normally grounded
2	RD+	LVPECL, Data output of receiver section
3	RD-	LVPECL, Reverse data output of receiver section
4	SD	Optical alarm of receiver section, High level when normal, Low level when no light.
5	V _{CC}	Positive power of receiver section, normally +3.3V
6	V _{CC}	Positive power of transmitter section, normally +3.3V
7	TD-	LVPECL, Reverse data input of transmitter section
8	TD+	LVPECL, Data input of transmitter section
9	Vee	Negative power of transmitter section, normally grounded

6 Package Information

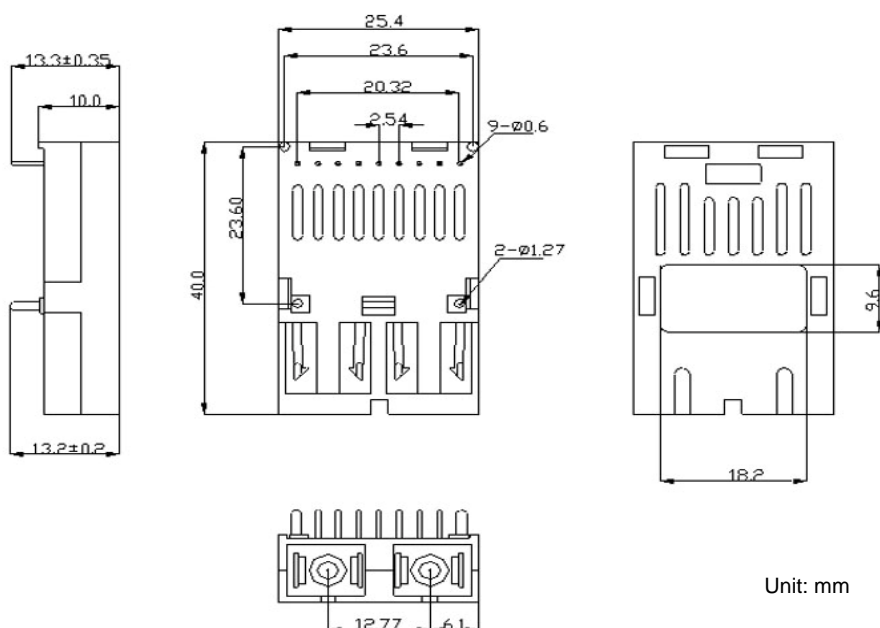

7 Recommended Circuit

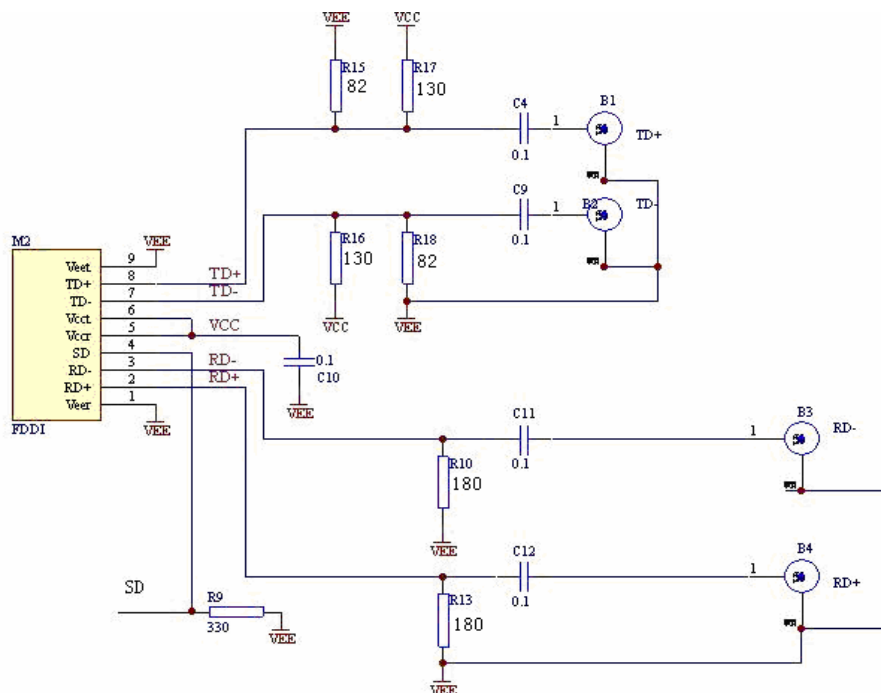

8 Ordering Information

Part Number	Product Description
ETR9155-31LR1A	Duplex SC 155Mb/s;40km,-40~85°C

Contact Information:

Address: 2F, Jianxing Building 3; Chaguang Industrial Park; West Shahe Road; Shenzhen; China;
 PC: 518055
 Tel: 86-755-86131609
 Fax: 86-755-26635026