

**Features:**

- 2 Compliant with ITU-T G.957,G.958 and RoHS
- 2 Multi-source package with Duplex LC Connector
- 2 Up to 155.52Mbps data rate
- 2 Eye Safety Designed to meet Laser Class1 (IEC60825-1)
- 2 850nm/1310nm/1550nm VCSEL/FP/DFB
- 2 Single-Mode / Multi-Mode can be selected
- 2 Single +3.3V Power Supply
- 2 Hot-Pluggable



**Applications:**

- 2 SONET OC-3/SDH STM-1
- 2 Fast Ethernet
- 2 Other optical links

**Specification:**

**I Electrical and Optical Characteristics (Condition: T<sub>a</sub>=T<sub>OP</sub>)**

Parameter	Symbol	Min.	Typ.	Max.	Unit
Transmitter Differential Input Volt	+/-TX_DAT	650		2000	mV p-p
Supply Current	I <sub>CC</sub>		200	250	mA
Tx_Disable Input Voltage – Low	V <sub>IL</sub>	0		0.8	V
Tx_Disable Input Voltage – High	V <sub>IH</sub>	2.0		V <sub>CC</sub>	V
Tx_Fault Output Voltage – Low	V <sub>OL</sub>	0		0.8	V
Tx_Fault Output Voltage – High	V <sub>OH</sub>	2.0		V <sub>CC</sub>	V
Receiver Differential Output Volt	+/-RX_DAT	0.4		2000	mV p-p
Rx_LOS Output Voltage- Low	V <sub>OL</sub>	0		0.8	V
Rx_LOS Output Voltage- High	V <sub>OH</sub>	2.0		V <sub>CC</sub>	V

**GSFP-03-3831M-1X (850nm VCSEL/2Km):**

TX Parameter	Symbol	Min	Typ	Max	Unit
Data Rate	B	-	155	-	Mb/s
Centre wavelength	λ <sub>c</sub>	830	850	860	nm
Output Spectral Width	Δλ	-	-	0.85	nm
Average Output Power	P <sub>o</sub>	-9	-	-3	dBm
Extinction Ratio	EXT	10	-	-	dB
Data Input Voltage-High	V <sub>IHS</sub>	V <sub>CC</sub> -1.16	-	V <sub>CC</sub> -0.89	V
Data Input Voltage -Low	V <sub>ILS</sub>	V <sub>CC</sub> -1.82	-	V <sub>CC</sub> -1.48	V
Supply Current	I <sub>CC</sub>	-	90	130	mA
Output Optical Eye	Compliant with ITU-T G.957				
RX Parameter	Symbol	Min	Typ	Max	Unit
Receive Sensitivity	P <sub>min</sub>	-	-	-24	dBm
Maximum Input Power	P <sub>MAX</sub>	-3	0	-	dBm
Signal Detection-Asserted	P <sub>H-L</sub>	-	-	-33	dBm
Signal Detection-Deserted	P <sub>L-H</sub>	-45	-	-	dBm
Output High Voltage	V <sub>OH</sub>	V <sub>CC</sub> -1.03	-	V <sub>CC</sub> -0.89	V
Output Low Voltage	V <sub>OL</sub>	V <sub>CC</sub> -1.82	-	V <sub>CC</sub> -1.63	V
Operating Wavelength	λ <sub>c</sub>	770	-	860	nm
Supply Current	I <sub>CC</sub>	-	80	110	mA

**GSFP-03-3311S-1X (1310nm FP/20Km):**

TX Parameter	Symbol	Min	Typ	Max	Unit
Data Rate	B	-	155	-	Mb/s
Centre wavelength	$\lambda_c$	1296	1310	1330	nm
Output Spectral Width	$\Delta\lambda$	-	-	4	nm
Average Output Power	$P_o$	-15	-10	-8	dBm
Extinction Ratio	EXT	10	-	-	dB
Data Input Voltage-High	$V_{IHS}$	$V_{cc}-1.16$	-	$V_{cc}-0.89$	V
Data Input Voltage -Low	$V_{ILS}$	$V_{cc}-1.82$	-	$V_{cc}-1.48$	V
Supply Current	$I_{CC}$	-	90	110	mA
Output Optical Eye	Compliant with ITU-T G.957				
RX Parameter	Symbol	Min	Typ	Max	Unit
Receive Sensitivity	$P_{min}$	-	-	-34	dBm
Maximum Input Power	$P_{MAX}$	-3	0	-	dBm
Signal Detection-Asserted	$P_{H-L}$	-	-	-36	dBm
Signal Detection-Deserted	$P_{L-H}$	-48	-	-	dBm
Output High Voltage	$V_{OH}$	$V_{cc}-1.03$	-	$V_{cc}-0.89$	V
Output Low Voltage	$V_{OL}$	$V_{cc}-1.82$	-	$V_{cc}-1.63$	V
Operating Wavelength	$\lambda_c$	1100	-	1600	nm
Supply Current	$I_{CC}$	-	80	110	mA

**GSFP-03-1311S-1X (1310nm FP/40Km):**

TX Parameter	Symbol	Min	Typ	Max	Unit
Data Rate	B	-	155	-	Mb/s
Centre wavelength	$\lambda_c$	1296	1310	1330	nm
Output Spectral Width	$\Delta\lambda$	-	-	4	nm
Average Output Power	$P_o$	-5	-3	0	dBm
Extinction Ratio	EXT	10	-	-	dB
Data Input Voltage-High	$V_{IHS}$	$V_{cc}-1.16$	-	$V_{cc}-0.89$	V
Data Input Voltage -Low	$V_{ILS}$	$V_{cc}-1.82$	-	$V_{cc}-1.48$	V
Supply Current	$I_{CC}$	-	90	110	mA
Output Optical Eye	Compliant with ITU-T G.957				
RX Parameter	Symbol	Min	Typ	Max	Unit
Receive Sensitivity	$P_{min}$	-	-37	-36	dBm
Maximum Input Power	$P_{MAX}$	-3	-	-	dBm
Signal Detection-Asserted	$P_{H-L}$	-	-	-36	dBm
Signal Detection-Deserted	$P_{L-H}$	-48	-	-	dBm
Output High Voltage	$V_{OH}$	$V_{cc}-1.03$	-	$V_{cc}-0.89$	V
Output Low Voltage	$V_{OL}$	$V_{cc}-1.82$	-	$V_{cc}-1.63$	V
Operating Wavelength	$\lambda_c$	1100	-	1600	nm
Supply Current	$I_{CC}$	-	80	110	mA

**GSFP-03-1521S-1X (1550nm DFB/80Km):**

TX Parameter	Symbol	Min	Typ	Max	Unit
Data Rate	B	-	155	-	Mb/s
Centre wavelength	$\lambda_c$	1480	1550	1580	nm
Output Spectral Width	$\Delta\lambda$	-	-	1	nm
Average Output Power	$P_o$	-5	-	0	dBm

Extinction Ratio	EXT	10	-	-	dB
Data Input Voltage-High	V <sub>IHS</sub>	V <sub>cc</sub> -1.16	-	V <sub>cc</sub> -0.89	V
Data Input Voltage -Low	V <sub>ILS</sub>	V <sub>cc</sub> -1.82	-	V <sub>cc</sub> -1.48	V
Supply Current	I <sub>CC</sub>	-	90	130	mA
Output Optical Eye	Compliant with ITU-T G.957				
<b>RX Parameter</b>	<b>Symbol</b>	<b>Min</b>	<b>Typ</b>	<b>Max</b>	<b>Unit</b>
Receive Sensitivity	P <sub>min</sub>	-	-	-36	dBm
Maximum Input Power	P <sub>MAX</sub>	-3	-	-	dBm
Signal Detection-Asserted	P <sub>H-L</sub>	-	-	-36	dBm
Signal Detection-Deserted	P <sub>L-H</sub>	-48	-	-	dBm
Output High Voltage	V <sub>OH</sub>	V <sub>cc</sub> -1.03	-	V <sub>cc</sub> -0.89	V
Output Low Voltage	V <sub>OL</sub>	V <sub>cc</sub> -1.82	-	V <sub>cc</sub> -1.63	V
Operating Wavelength	λ <sub>c</sub>	1100	-	1600	nm
Supply Current	I <sub>CC</sub>	-	80	110	mA

### I Absolute Maximum Ratings (T<sub>C</sub>=25° C)

Parameter	Symbol	Min	Max	Unit
Storage Temperature	T <sub>ST</sub>	-40	+85	°C
Operating Temperature	T <sub>IP</sub>	0	+70	°C
Operating Temperature		-40	+85	
Input Voltage	T <sub>CC</sub>	0	5	V

### I Recommend Operation Environment:

Parameter	Symbol	Min	Typ.	Max	Unit
Supply Voltage	V <sub>CC</sub>	+3.0	3.3	+3.6	V
Operating Temperature	T <sub>OP</sub>	0	-	+70	°C
Operating Temperature		-40	-	+85	

### Timing Characteristics:

Parameter	Symbol	Min.	Typ.	Max.	Unit
TX_DISABLE Assert Time	t <sub>off</sub>		3	10	usec
TX_DISABLE Negate Time	t <sub>on</sub>		0.5	1	msec
Time to initialize include reset of TX_FAULT	t <sub>int</sub>		30	300	msec
TX_FAULT from fault to assertion	t <sub>fault</sub>		20	100	usec
TX_DISBEL time to start reset	t <sub>reset</sub>	10			usec
Receiver Loss of Signal Assert Time (off to On)	T <sub>A,RX_LOS</sub>			100	usec
Receiver Loss of Signal Assert Time (on to off)	T <sub>d,RX_LOS</sub>			100	usec

**Block Diagram of Transceiver:**

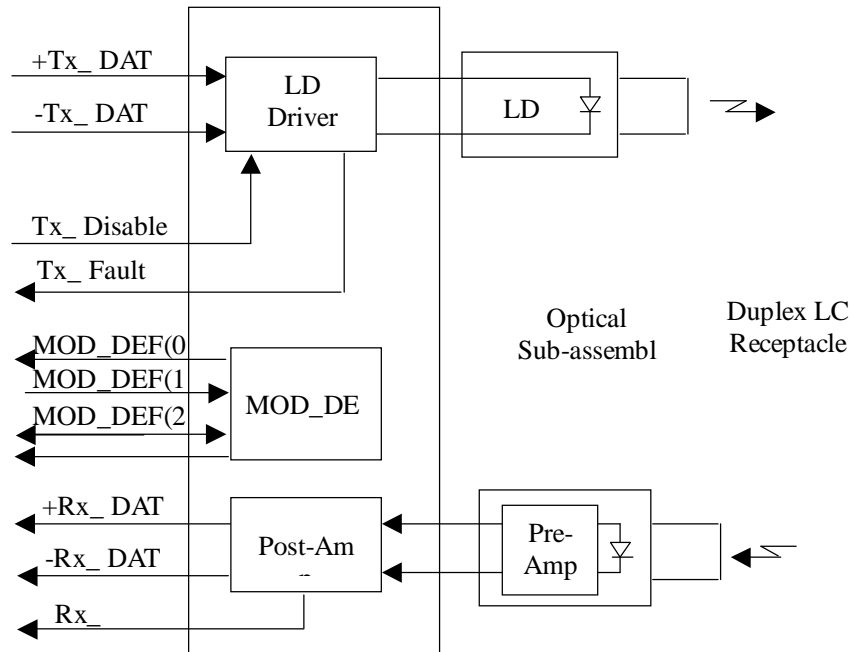

**Pin Assignment:**

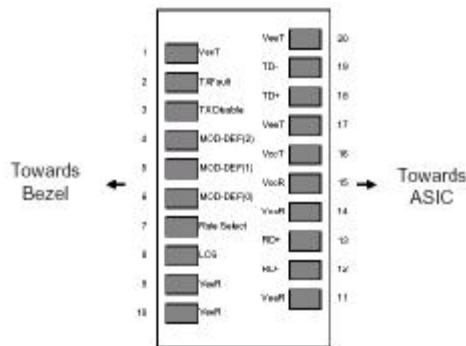

**Pin out of Connector Block on Host Board**

**Pin Description:**

Pin	Signal Name	Description	Plug Seq.	Notes
1	V <sub>EET</sub>	Transmitter Ground	1	
2	T <sub>FAULT</sub>	Transmitter Fault Indication	3	Note1
3	T <sub>DIS</sub>	Transmitter Disable	3	Note2, Module disables on high or open
4	MOD_DEF(2)	SDA Serial Data Signal	3	Note3, 2 wire serial ID interface
5	MOD_DEF(1)	SCL Serial Clock Signal	3	Note3, 2 wire serial ID interface
6	MOD_DEF(0)	TTL Low	3	Note3, Grounded in Module
7	Rate Select	Select between full or reduced receiver bandwidth	3	NO connection required, Low or Open-reduced bandwidth, High-full bandwidth
8	LOS	Loss of Signal indication, Logic 0 indicate normal operation	3	Note 5
9	V <sub>EER</sub>	Receiver ground	1	Note 6
10	V <sub>EER</sub>	Receiver ground	1	Note 6

11	V <sub>EER</sub>	Receiver ground	1	Note 6
12	RX <sub>-</sub>	Receiver Data Bar, Differential PECL, ac coupled	3	Note 7
13	RX <sub>+</sub>	Receiver Data, Differential PECL, ac coupled	3	Note 7
14	V <sub>EER</sub>	Receiver ground	1	Note 6
15	V <sub>CCR</sub>	Receiver Power Supply	2	3.3V <sub>±5%</sub> , Note 8
16	V <sub>CCT</sub>	Transmitter Power Supply	2	3.3V <sub>±5%</sub> , Note 8
17	V <sub>EET</sub>	Transmitter Ground	1	Note 6
18	TX <sub>+</sub>	Receiver Data, Differential PECL, ac coupled	3	Note 9
19	TX <sub>-</sub>	Receiver Data Bar, Differential PECL, ac coupled	3	Note 9
20	V <sub>EET</sub>	Transmitter Ground	1	Note 6

**Notes:**

Plug Seq.: Pin engagement sequence during hot plugging.

1) TX Fault is an open collector/drain output, which should be pulled up with a 4.7K – 10K resistor on the host board. Pull up voltage between 2.0V and V<sub>ccT</sub>, R+0.3V. When high, output indicates a laser fault of some kind. Low indicates normal operation. In the low state, the output will be pulled to < 0.8V.

2) TX disable is an input that is used to shut down the transmitter optical output. It is pulled up within the module with a 4.7 K 10 K resistor. Its states are:

Low (0 to 0.8V): Transmitter on

(>0.8, < 2.0V): Undefined

High (2.0 to 3.465V): Transmitter Disabled

Open: Transmitter Disabled

3) Mod-Def 0,1,2. These are the module definition pins. They should be pulled up with a 4.7K to 10K resistor on the host board. The pull-up voltage shall be V<sub>ccT</sub> or V<sub>ccR</sub>

Mod-Def 0 is grounded by the module

Mod-Def 1 is the clock line of two wire serial interface for serial ID

Mod-Def 2 is the data line of two wire serial interface for serial ID

4) This is an optional input used to control the receiver bandwidth for compatibility with multiple data rates (most likely Fibre Channel 1x and 2x Rates). If implemented, the input will be internally pulled down with > 30k resistor. The input states are:

Low (0 to 0.8V): Reduced Bandwidth

(>0.8, < 2.0V): Undefined

High (2.0 to 3.465V): Full Bandwidth

Open: Reduced Bandwidth

5) LOS (Loss of Signal) is an open collector/drain output, which should be pulled up with a 4.7K to 10K resistor. Pull up voltage between 2.0V and V<sub>ccT</sub>, R+0.3V. When high, this output indicates the received optical power is below the worst-case receiver sensitivity (as defined by the standard in use). Low indicates normal operation. In the low state, the output will be pulled to <0.8V.

6) V<sub>eeR</sub> and V<sub>eeT</sub> may be internally connected within the SFP module.

7) RD<sub>-/+</sub>: These are the differential receiver outputs. They are AC coupled 100 differential lines which should be terminated with 100 (differential) at the user SERDES. The AC coupling is done inside the module and is thus not required on the host board. The voltage swing on these lines will be between 370 and 2000 mV differential (185 to 1000 mV single ended) when properly terminated.

8) V<sub>ccR</sub> and V<sub>ccT</sub> are the receiver and transmitter power supplies. They are defined as 3.3V ±5% at the SFP connector pin. Maximum supply current is 300 mA. Recommended host board power supply filtering is shown below. Inductors with DC resistance of less than 1 Ω should be used in order to maintain the required voltage at the SFP input pin with 3.3V supply voltage. When the recommended supply filtering network is used, hot plugging of the SFP transceiver module will result in an inrush current of no more than 30 mA greater than the steady state value. V<sub>ccR</sub> and V<sub>ccT</sub> may be internally connected within the SFP transceiver module.

9) TD<sub>-/+</sub>: These are the differential transmitter inputs. They are AC-coupled, differential lines with 100 differential termination inside the module. The AC coupling is done inside the module and is thus not required on the host board. The inputs will accept differential swings of 500 to 2400 mV (250 to 1200 mV single-ended), though it is recommended that values between 500 and 1200 mV differential (250 to 600 mV single-ended) be used for best EMI performance.

**Serial ID Memory Contents:**

Data Address	Length (Byte)	Name of Length	Description and Contents
<b>Base ID Fields</b>			
0	1	Identifier	Type of Serial transceiver (03h=SFP)
1	1	Reserved	Extended identifier of type serial transceiver (04h)
2	1	Connector	Code of optical connector type (07=SC)
3-10	8	Transceiver	Gigabit Ethernet 1000Base-SX & Fiber Channel
11	1	Encoding	8B10B (01h)
12	1	BR,Nominal	Nominal baud rate, unit of 100Mbps
13-14	2	Reserved	(0000h)
15	1	Length(9um)	Link length supported for 9/125um fiber, units of 100m
16	1	Length(50um)	Link length supported for 50/125um fiber, units of 10m
17	1	Length(62.5um)	Link length supported for 62.5/125um fiber, units of 10m
18	1	Length(Copper)	Link length supported for copper, units of meters
19	1	Reserved	
20-35	16	Vendor Name	SFP vendor name: Greatway
36	1	Reserved	
37-39	3	Vendor OUI	SFP transceiver vendor OUI ID
40-55	16	Vendor PN	Part Number: "HCDTR-xxxxxx" (ASCII)
56-59	4	Vendor rev	Revision level for part number
60-62	3	Reserved	
63	1	CCID	Least significant byte of sum of data in address 0-62
<b>Extended ID Fields</b>			
64-65	2	Option	Indicates which optical SFP signals are implemented (001Ah = LOS, TX_FAULT, TX_DISABLE all supported)
66	1	BR, max	Upper bit rate margin, units of %
67	1	BR, min	Lower bit rate margin, units of %
68-83	16	Vendor SN	Serial number (ASCII)
84-91	8	Date code	Greatway's Manufacturing date code
92-94	3	Reserved	
95	1	CCEX	Check code for the extended ID Fields (addresses 64 to 94)
<b>Vendor Specific ID fields</b>			
96-127	32	Readable	Greatway specific date, read only

**Recommended Circuit:**

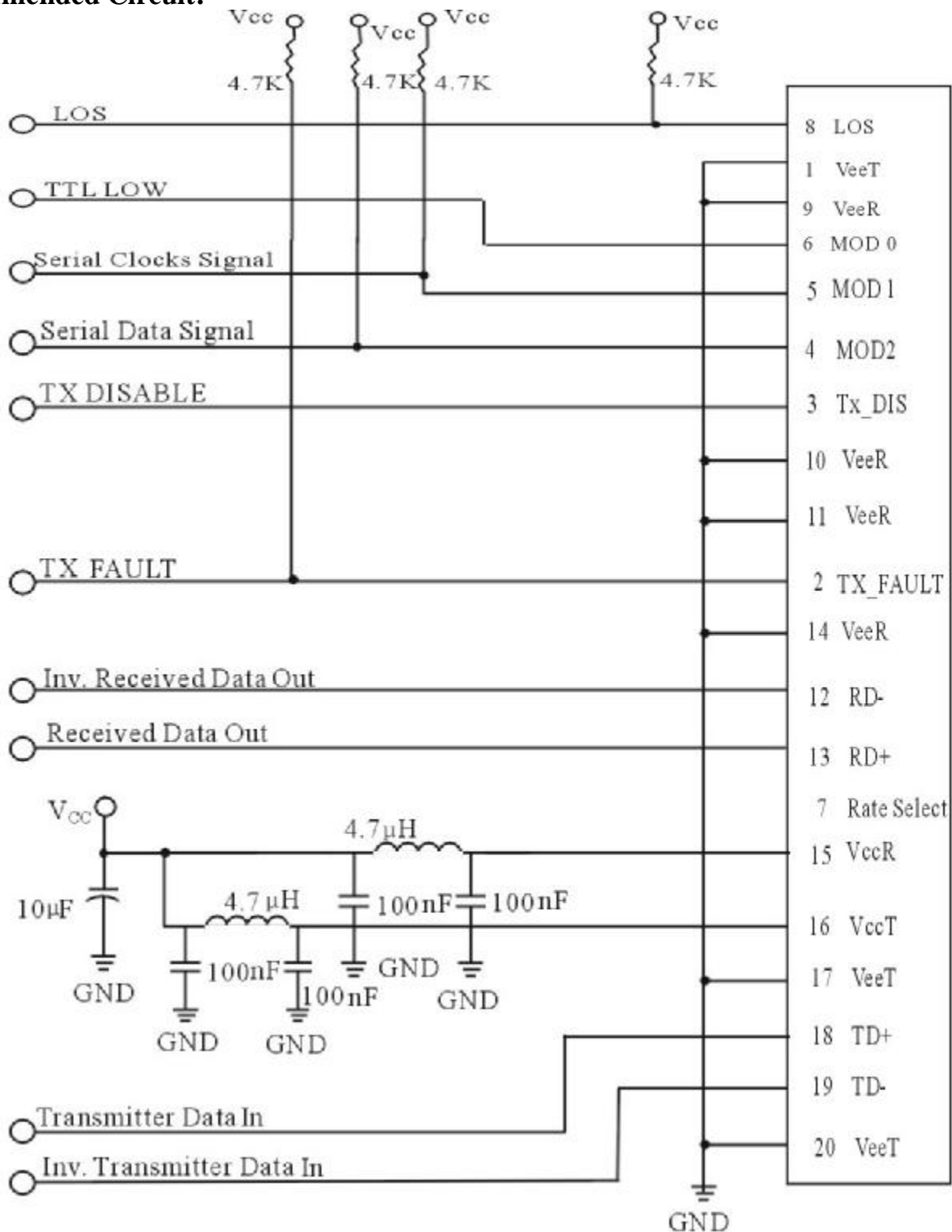

**Mechanical Dimensions:**

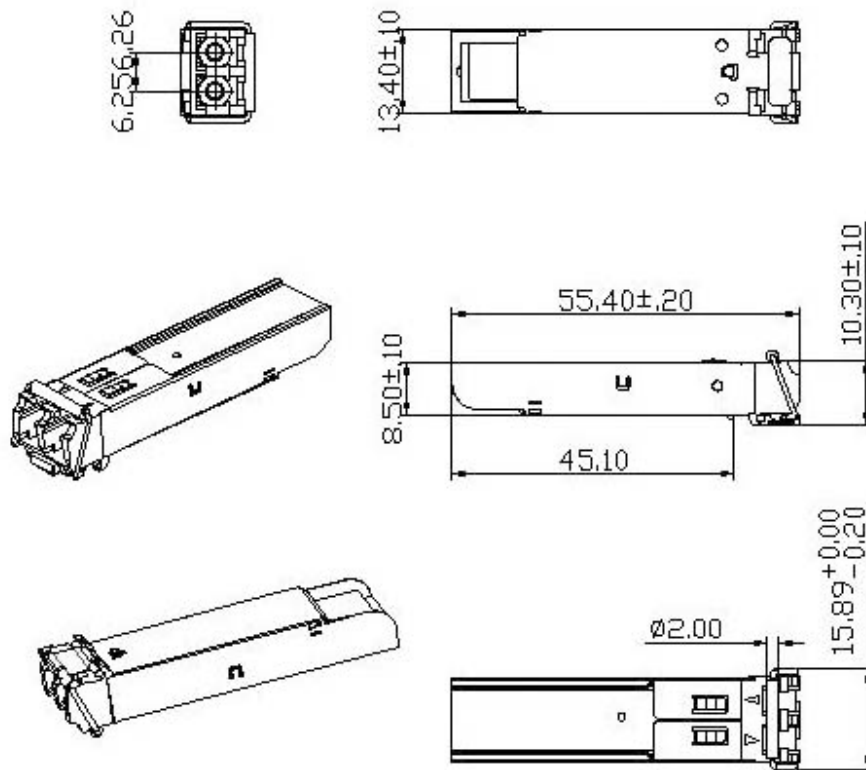

**Ordering Information:**

