

Features:

- 2 Compliance with ITU-T G.957, G.958 and Bellcore TA-NWT-00098:
- 2 Up to 622Mbps data links
- 2 Multi-source package with Duplex LC Connector
- 2 Eye Safety Designed to meet Laser Class1 (IEC60825-1)
- 2 Single +3.3V Power Supply
- 2 Hot-Pluggable
- 2 Monitoring interface compliant with SFF-8472
- 2 Complies with RoHS



Applications:

- 2 SONET/SDH system
- 2 ATM
- 2 Other optical links

Specification:

I Electrical and Optical Characteristics (Condition: T_c=T_{OP})

Parameter	Symbol	Min.	Typ	Max.	Unit
Transmitter Differential Input Volt	+/-TX_DAT	650		2000	mV p-p
Supply Current	I _{CC}		200	250	mA
Tx_Disable Input Voltage – Low	V _{IL}	0		0.8	V
Tx_Disable Input Voltage – High	V _{IH}	2.0		V _{CC}	V
Tx_Fault Output Voltage – Low	V _{OL}	0		0.8	V
Tx_Fault Output Voltage – High	V _{OH}	2.0		V _{CC}	V
Receiver Differential Output Volt	+/-RX_DAT	0.4		2000	mV p-p
Rx_LOS Output Voltage- Low	V _{OL}	0		0.8	V
Rx_LOS Output Voltage- High	V _{OH}	2.0		V _{CC}	V

GSFP-12-3311S-1X (1310nm FP/20Km):

TX Parameter	Symbol	Min	Typ	Max	Unit
Data Rate	B	-	622	-	Mb/s
Centre wavelength	λ _c	1296	1310	1330	nm
Output Spectral Width	Δλ	-	-	4	nm
Average Output Power	P _o	-15	-10	-8	dBm
Extinction Ratio	EXT	10	-	-	dB
Data Input Voltage-High	V _{IHS}	V _{CC} -1.16	-	V _{CC} -0.89	V
Data Input Voltage -Low	V _{ILS}	V _{CC} -1.82	-	V _{CC} -1.48	V
Supply Current	I _{CC}	-	90	110	mA
Output Optical Eye	Compliant with ITU-T G.957				
RX Parameter	Symbol	Min	Typ	Max	Unit
Receive Sensitivity	P _{min}	-	-	-28	dBm
Maximum Input Power	P _{MAX}	-3	0	-	dBm
Signal Detection-Asserted	P _{H-L}	-45	-	-	dBm
Signal Detection-Deserted	P _{L-H}	-	-	-28	dBm
Operating Wavelength	λ _c	1100	-	1600	nm
Supply Current	I _{CC}	-	80	110	mA

GSFP-12-1311S-1X (1310nm FP/40Km):

TX Parameter	Symbol	Min	Typ	Max	Unit
Data Rate	B	-	622	-	Mb/s
Centre wavelength	λ _c	1296	1310	1330	nm

Output Spectral Width	$\Delta \lambda$	-	-	4	nm
Average Output Power	P_o	-3	-1	+2	dBm
Extinction Ratio	EXT	10	-	-	dB
Data Input Voltage-High	V_{IHS}	$V_{cc}-1.16$	-	$V_{cc}-0.89$	V
Data Input Voltage -Low	V_{ILS}	$V_{cc}-1.82$	-	$V_{cc}-1.48$	V
Supply Current	I_{CC}	-	90	110	mA
Output Optical Eye	Compliant with ITU-T G.957				
RX Parameter	Symbol	Min	Typ	Max	Unit
Receive Sensitivity	P_{min}	-	-	-28	dBm
Maximum Input Power	P_{MAX}	-3	0	-	dBm
Signal Detection-Asserted	P_{H-L}	-45	-	-	dBm
Signal Detection-Deserted	P_{L-H}	-	-	-30	dBm
Operating Wavelength	λ_c	1100	-	1600	nm
Supply Current	I_{CC}	-	80	110	mA

GSFP-12-1521S-1X (1550nm DFB/80Knm):

TX Parameter	Symbol	Min	Typ	Max	Unit
Data Rate	B	-	622	-	Mb/s
Output Center Wavelength	λ_c	1480	1550	1580	nm
Output Spectral Width	$\Delta \lambda$	-	-	1	nm
Average Output Power	P_o	-2	-	+3	dBm
Extinction Ratio	EXT	10	-	-	dB
Data Input Voltage-High	V_{IHS}	$V_{cc}-1.16$	-	$V_{cc}-0.89$	V
Data Input Voltage -Low	V_{ILS}	$V_{cc}-1.82$	-	$V_{cc}-1.48$	V
Supply Current	I_{CC}	-	90	130	mA
Output Optical Eye	Compliant with ITU-T G.957				
RX Parameter	Symbol	Min	Typ	Max	Unit
Receive Sensitivity	P_{min}	-	-	-28	dBm
Maximum Input Power	P_{MAX}	-3	-	-	dBm
Signal Detection-Asserted	P_{H-L}	-42	-	-	dBm
Signal Detection-Deserted	P_{L-H}	-	-	-31	dBm
Operating Wavelength	λ_c	1100	-	1600	nm
Supply Current	I_{CC}	-	80	110	mA

I Absolute Maximum Ratings ($T_C=25^\circ C$)

Parameter	Symbol	Min	Max	Unit
Storage Temperature	T_{ST}	-40	+85	$^\circ C$
Operating Temperature	T_{IP}	0	+70	$^\circ C$
Operating Temperature		-40	+85	
Input Voltage	T_{CC}	0	5	V

I Recommend Operation Environment:

Parameter	Symbol	Min	typ	Max	Unit
Supply Voltage	V_{CC}	+3.0	3.3	+3.6	V
Operating Temperature	T_{OP}	0	-	+70	$^\circ C$
Operating Temperature		-40	-	+85	

Timing Characteristics:

Parameter	Symbol	Min.	Typ	Max.	Unit
TX_DISABLE Assert Time	t_off		3	10	usec
TX_DISABLE Negate Time	t_on		0.5	1	msec
Time to initialize include reset of TX_FAULT	t_int		30	300	msec
TX_FAULT from fault to assertion	t_fault		20	100	usec
TX_DISBEL time to start reset	t_reset	10			usec
Receiver Loss of Signal Assert Time (off to On)	T _A ,RX_LOS			100	usec
Receiver Loss of Signal Assert Time (on to off)	T _d ,RX_LOS			100	usec

Digital Diagnostic Monitor Characteristics

Parameter.	Min	Unit
Tx Output Power Accuracy	±3.0	dBm
Rx Input Power Accuracy	±3.0	dBm
Laser Bias Current Accuracy	±1.0	%
Transceiver Internal Temperature Accuracy	±3.0	°C
Transceiver Internal Supply Voltage Accuracy	±0.1	V

Block Diagram of Transceiver

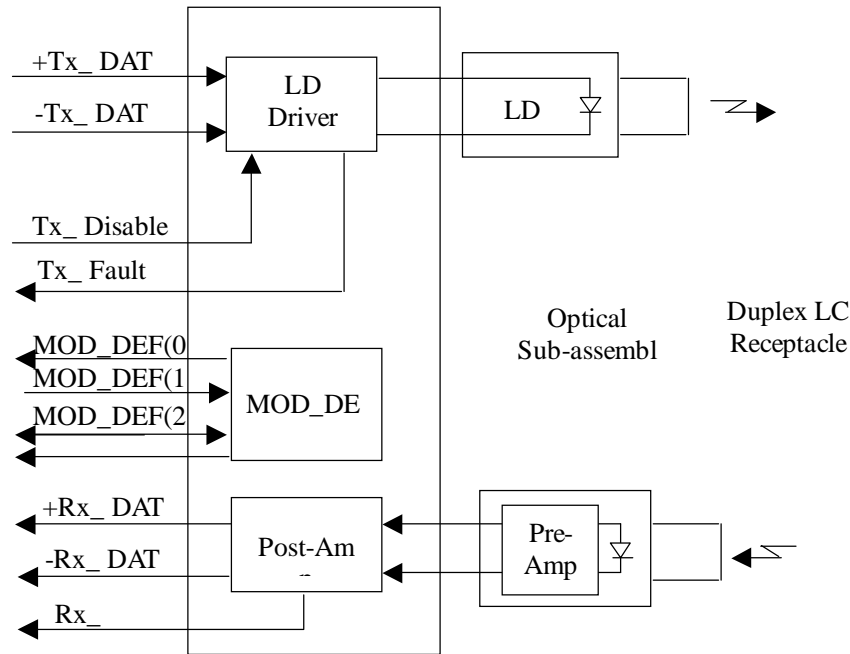

Pin Assignment:

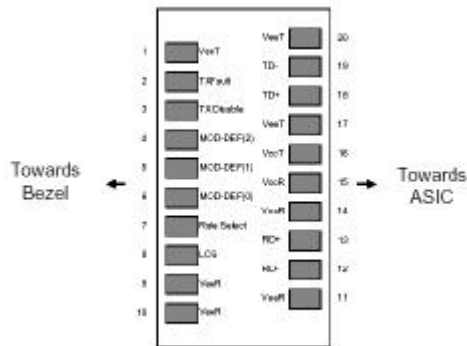

Pin out of Connector Block on Host Board

Pin Description:

Pin	Signal Name	Description	Plug Seq.	Notes
1	V _{EET}	Transmitter Ground	1	
2	T _{FAULT}	Transmitter Fault Indication	3	Note1
3	T _{DIS}	Transmitter Disable	3	Note2, Module disables on high or open
4	MOD_DEF(2)	SDA Serial Data Signal	3	Note3, 2 wire serial ID interface
5	MOD_DEF(1)	SCL Serial Clock Signal	3	Note3, 2 wire serial ID interface
6	MOD_DEF(0)	TTL Low	3	Note3, Grounded in Module
7	Rate Select	Select between full or reduced receiver bandwidth	3	No connection required, Low or open-reduced bandwidth, High-full bandwidth
8	LOS	Loss of Signal indication, Logic 0 indicate normal operation	3	Note 5
9	V _{EER}	Receiver ground	1	Note 6

10	V _{EER}	Receiver ground	1	Note 6
11	V _{EER}	Receiver ground	1	Note 6
12	RX ₋	Receiver Data Bar, Differential PECL, ac coupled	3	Note 7
13	RX ₊	Receiver Data, Differential PECL, ac coupled	3	Note 7
14	V _{EER}	Receiver ground	1	Note 6
15	V _{CCR}	Receiver Power Supply	2	3.3V \pm 5%, Note 8
16	V _{CCT}	Transmitter Power Supply	2	3.3V \pm 5%, Note 8
17	V _{EET}	Transmitter Ground	1	Note 6
18	TX ₊	Receiver Data, Differential PECL, ac coupled	3	Note 9
19	TX ₋	Receiver Data Bar, Differential PECL, ac coupled	3	Note 9
20	V _{EET}	Transmitter Ground	1	Note 6

Notes:

Plug Seq.: Pin engagement sequence during hot plugging.

1) TX Fault is an open collector/drain output, which should be pulled up with a 4.7K – 10K resistor on the host board. Pull up voltage between 2.0V and V_{ccT}, R+0.3V. When high, output indicates a laser fault of some kind. Low indicates normal operation. In the low state, the output will be pulled to < 0.8V.

2) TX disable is an input that is used to shut down the transmitter optical output. It is pulled up within the module with a 4.7 K resistor. Its states are:

Low (0 to 0.8V): Transmitter on

(>0.8, < 2.0V): Undefined

High (2.0 to 3.465V): Transmitter Disabled

Open: Transmitter Disabled

3) Mod-Def 0,1,2. These are the module definition pins. They should be pulled up with a 4.7K to 10K resistor on the host board. The pull-up voltage shall be V_{ccT} or V_{ccR}

Mod-Def 0 is grounded by the module to indicate that the module is present

Mod-Def 1 is the clock line of two wire serial interface for serial ID

Mod-Def 2 is the data line of two wire serial interface for serial ID

4) This is an optional input used to control the receiver bandwidth for compatibility with multiple data rates (most likely Fiber Channel 1x and 2x Rates). If implemented, the input will be internally pulled down with > 30k resistor. The input states are:

Low (0 to 0.8V): Reduced Bandwidth

(>0.8, < 2.0V): Undefined

High (2.0 to 3.465V): Full Bandwidth

Open: Reduced Bandwidth

5) LOS (Loss of Signal) is an open collector/drain output, which should be pulled up with a 4.7K to 10K resistor. Pull up voltage between 2.0V and V_{ccT}, R+0.3V. When high, this output indicates the received optical power is below the worst-case receiver sensitivity (as defined by the standard in use). Low indicates normal operation. In the low state, the output will be pulled to <0.8V.

6) V_{eeR} and V_{eeT} may be internally connected within the SFP module.

7) RD_{-/+}: These are the differential receiver outputs. They are AC coupled 100 differential lines which should be terminated with 100 (differential) at the user SERDES. The AC coupling is done inside the module and is thus not required on the host board. The voltage swing on these lines will be between 370 and 2000 mV differential (185 to 1000 mV single ended) when properly terminated.

8) V_{ccR} and V_{ccT} are the receiver and transmitter power supplies. They are defined as 3.3V \pm 5% at the SFP connector pin. Maximum supply current is 300 mA. Recommended host board power supply filtering is shown below. Inductors with DC resistance of less than 1 Ω should be used in order to maintain the required voltage at the SFP input pin with 3.3V supply voltage. When the recommended supply filtering network is used, hot plugging of the SFP transceiver module will result in an inrush current of no more than 30 mA greater than the steady state value. V_{ccR} and V_{ccT} may be internally connected within the SFP transceiver module.

9) TD_{-/+}: These are the differential transmitter inputs. They are AC-coupled, differential lines with 100 differential termination inside the module. The AC coupling is done inside the module and is thus not required on the host board. The inputs will accept differential swings of 500 to 2400 mV (250 to 1200 mV single-ended), though it is recommended that values between 500 and 1200 mV differential (250 to 600 mV single-ended) be used for best EMI

performance.

Serial ID Memory Contents:

Data Address	Length (Byte)	Name of Length	Description and Contents
Base ID Fields			
0	1	Identifier	Type of Serial transceiver (03h=SFP)
1	1	Reserved	Extended identifier of type serial transceiver (04h)
2	1	Connector	Code of optical connector type (07=SC)
3-10	8	Transceiver	Gigabit Ethernet 1000Base-SX & Fiber Channel
11	1	Encoding	8B10B (01h)
12	1	BR,Nominal	Nominal baud rate, unit of 100Mbps
13-14	2	Reserved	(0000h)
15	1	Length(9um)	Link length supported for 9/125um fiber, units of 100m
16	1	Length(50um)	Link length supported for 50/125um fiber, units of 10m
17	1	Length(62.5um)	Link length supported for 62.5/125um fiber, units of 10m
18	1	Length(Copper)	Link length supported for copper, units of meters
19	1	Reserved	
20-35	16	Vendor Name	SFP vendor name: Greatway
36	1	Reserved	
37-39	3	Vendor OUI	SFP transceiver vendor OUI ID
40-55	16	Vendor PN	Part Number: "HCDTR-xxxxxx" (ASCII)
56-59	4	Vendor rev	Revision level for part number
60-62	3	Reserved	
63	1	CCID	Least significant byte of sum of data in address 0-62
Extended ID Fields			
64-65	2	Option	Indicates which optical SFP signals are implemented (001Ah = LOS, TX_FAULT, TX_DISABLE all supported)
66	1	BR, max	Upper bit rate margin, units of %
67	1	BR, min	Lower bit rate margin, units of %
68-83	16	Vendor SN	Serial number (ASCII)
84-91	8	Date code	Greatway's Manufacturing date code
92-94	3	Reserved	
95	1	CCEX	Check code for the extended ID Fields (addresses 64 to 94)
Vendor Specific ID fields			
96-127	32	Readable	Greatway specific date, read only

Serial ID Memory Contents: (A2H)

Address	# Bytes	Name	Description
00-01	2	Temp High Alarm	MSB at low address
02-03	2	Temp Low Alarm	MSB at low address
04-05	2	Temp High Warning	MSB at low address
06-07	2	Temp Low Warning	MSB at low address
08-09	2	Voltage High Alarm	MSB at low address
10-11	2	Voltage Low Alarm	MSB at low address
12-13	2	Voltage High Warning	MSB at low address
14-15	2	Voltage Low Warning	MSB at low address
16-17	2	Bias High Alarm	MSB at low address
18-19	2	Bias Low Alarm	MSB at low address
20-21	2	Bias High Warning	MSB at low address
22-23	2	Bias Low Warning	MSB at low address
24-25	2	TX Power High Alarm	MSB at low address

26-27	2	TX Power Low Alarm	MSB at low address
28-29	2	TX Power High Warning	MSB at low address
30-31	2	TX Power Low Warning	MSB at low address
32-33	2	RX Power High Alarm	MSB at low address
34-35	2	RX Power Low Alarm	MSB at low address
36-37	2	RX Power High Warning	MSB at low address
38-39	2	RX Power Low Warning	MSB at low address
40-55	16	Reserved	Reserved for future monitored quantities

Address	# Bytes	Name	Description
56-59	4	Rx_PWR(4)	Single precision floating point calibration data - Rx optical power. Bit 7 of byte 56 is MSB. Bit 0 of byte 59 is LSB.
60-63	4	Rx_PWR(3)	Single precision floating point calibration data - Rx optical power. Bit 7 of byte 60 is MSB. Bit 0 of byte 63 is LSB.
64-67	4	Rx_PWR(2)	Single precision floating point calibration data, Rx optical power. Bit 7 of byte 64 is MSB, bit 0 of byte 67 is LSB.
68-71	4	Rx_PWR(1)	Single precision floating point calibration data, Rx optical power. Bit 7 of byte 68 is MSB, bit 0 of byte 71 is LSB.
72-75	4	Rx_PWR(0)	Single precision floating point calibration data, Rx optical power. Bit 7 of byte 72 is MSB, bit 0 of byte 75 is LSB.
76-77	2	Tx_I(Slope)	Fixed decimal (unsigned) calibration data, laser bias current. Bit 7 of byte 76 is MSB, bit 0 of byte 77 is LSB.
78-79	2	Tx_I(Offset)	Fixed decimal (signed two's complement) calibration data, laser bias current. Bit 7 of byte 78 is MSB, bit 0 of byte 79 is LSB
80-81	2	Tx_PWR(Slope)	Fixed decimal (unsigned) calibration data, transmitter coupled output power. Bit 7 of byte 80 is MSB, bit 0 of byte 81 is LSB.
82-83	2	Tx_PWR(Offset)	Fixed decimal (signed two's complement) calibration data, transmitter coupled output power. Bit 7 of byte 82 is MSB, bit 0 of byte 83 is LSB.
84-85	2	T(Slope)	Fixed decimal (unsigned) calibration data, internal module temperature. Bit 7 of byte 84 is MSB, bit 0 of byte 85 is LSB.
86-87	2	T(Offset)	Fixed decimal (signed two's complement) calibration data, internal module temperature. Bit 7 of byte 86 is MSB, bit 0 of byte 87 is LSB.
88-89	2	V(Slope)	Fixed decimal (unsigned) calibration data, internal module supply voltage. Bit 7 of byte 88 is MSB, bit 0 of byte 89 is LSB.
90-91	2	V(Offset)	Fixed decimal (signed two's complement) calibration data, internal module supply voltage. Bit 7 of byte 90 is MSB. Bit 0 of byte 91 is LSB.
92-95	4	Reserved	Reserved

Byte	Bit	Name	Description
Converted analog values. Calibrated 16 bit data			
96	All	Temperature MSB	Internally measured module temperature.
97	All	Temperature LSB	
98	All	Vcc MSB	Internally measured supply voltage in transceiver.
99	All	Vcc LSB	
100	All	TX Bias MSB	Internally measured TX Bias Current.
101	All	TX Bias LSB	
102	All	TX Power MSB	Measured TX output power.
103	All	TX Power LSB	
104	All	RX Power MSB	Measured RX input power.

105	All	RX Power LSB	
106	All	Reserved MSB	Reserved for 1st future definition of digitized analog input
107	All	Reserved LSB	Reserved for 1st future definition of digitized analog input
108	All	Reserved MSB	Reserved for 2nd future definition of digitized analog input
109	All	Reserved LSB	Reserved for 2nd future definition of digitized analog input
Optional Status/Control Bits			
110	7	TX Disable State	Digital state of the TX Disable Input Pin. Not supported.
110	6	Soft TX Disable	Read/write bit that allows software disable of laser. Not supported.
110	5	Reserved	
110	4	RX Rate Select State	Digital state of the SFP RX Rate Select Input Pin. Not supported.
110	3	Soft RX Rate Select	Read/write bit that allows software RX rate select. Not supported.
110	2	TX Fault	Digital state of the TX Fault Output Pin.
110	1	LOS	Digital state of the LOS Output Pin.
110	0	Data Ready	Indicates transceiver has achieved power up and data is ready
111	7-0	Reserved	Reserved.

Byte	Bit	Name	Description
Reserved Optional Alarm and Warning Flag Bits			
112	7	Temp High Alarm	Set when internal temperature exceeds high alarm level.
112	6	Temp Low Alarm	Set when internal temperature is below low alarm level.
112	5	Vcc High Alarm	Set when internal supply voltage exceeds high alarm level.
112	4	Vcc Low Alarm	Set when internal supply voltage is below low alarm level.
112	3	TX Bias High Alarm	Set when TX Bias current exceeds high alarm level.
112	2	TX Bias Low Alarm	Set when TX Bias current is below low alarm level.
112	1	TX Power High Alarm	Set when TX output power exceeds high alarm level.
112	0	TX Power Low Alarm	Set when TX output power is below low alarm level.
113	7	RX Power High Alarm	Set when Received Power exceeds high alarm level.
113	6	RX Power Low Alarm	Set when Received Power is below low alarm level.
113	5	Reserved Alarm	
113	4	Reserved Alarm	
113	3	Reserved Alarm	
113	2	Reserved Alarm	
113	1	Reserved Alarm	
113	0	Reserved Alarm	
114	All	Reserved	
115	All	Reserved	
116	7	Temp High Warning	Set when internal temperature exceeds high warning level.
116	6	Temp Low Warning	Set when internal temperature is below low warning level.
116	5	Vcc High Warning	Set when internal supply voltage exceeds high warning level.
116	4	Vcc Low Warning	Set when internal supply voltage is below low warning level.
116	3	TX Bias High Warning	Set when TX Bias current exceeds high warning level.
116	2	TX Bias Low Warning	Set when TX Bias current is below low warning level.
116	1	TX Power High Warning	Set when TX output power exceeds high warning level.
116	0	TX Power Low Warning	Set when TX output power is below low warning level.
117	7	RX Power High Warning	Set when Received Power exceeds high warning level.
117	6	RX Power Low Warning	Set when Received Power is below low warning level.
117	5	Reserved Warning	
117	4	Reserved Warning	
117	3	Reserved Warning	
117	2	Reserved Warning	
117	1	Reserved Warning	

117	0	Reserved Warning	
118	All	Reserved	
119	All	Reserved	

Byte	# Byte	Name	Description
120-127	8	Vendor Specific	00h.
128-255	128		Writable Memory

Recommended Circuit:

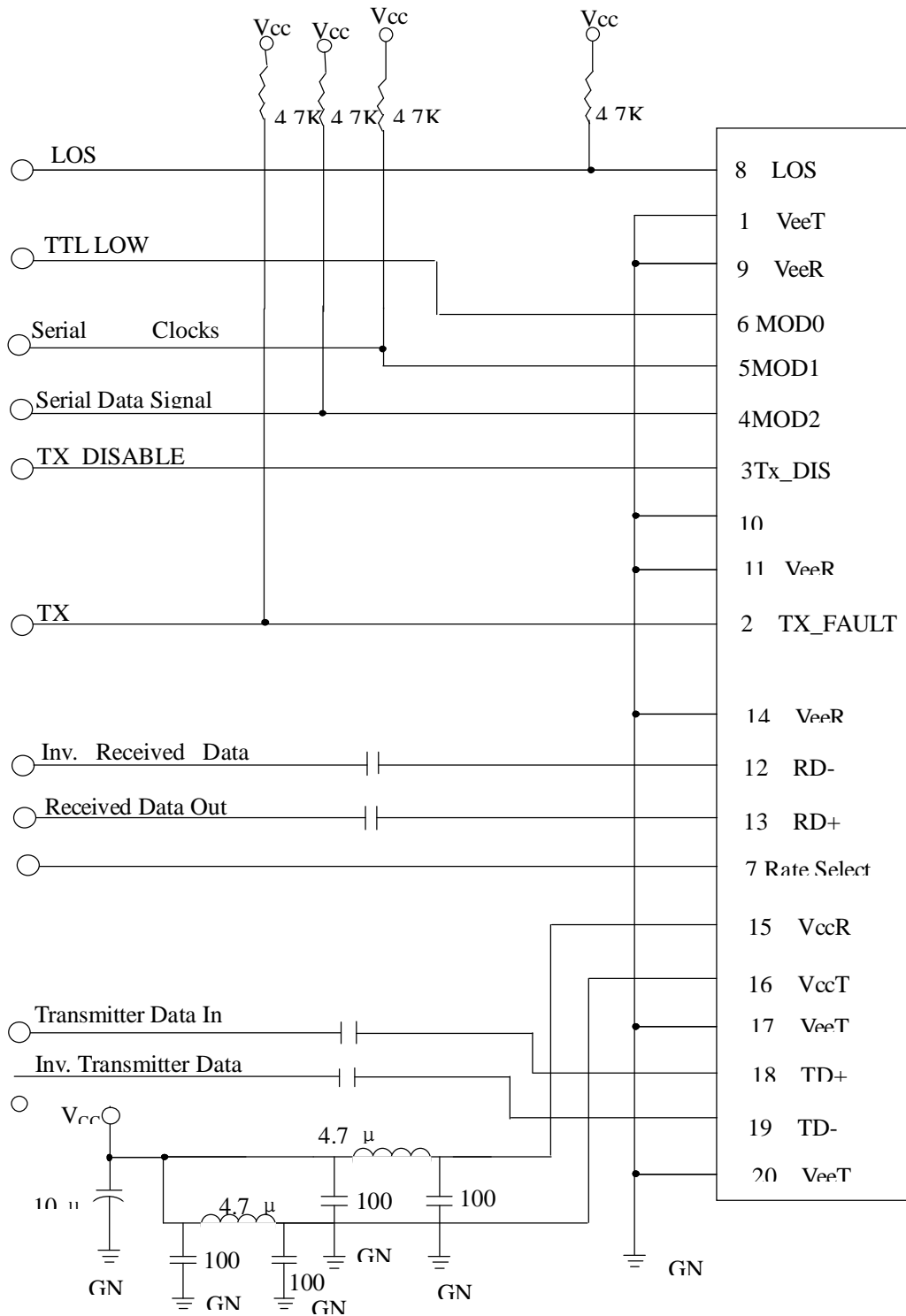

Mechanical Dimensions:

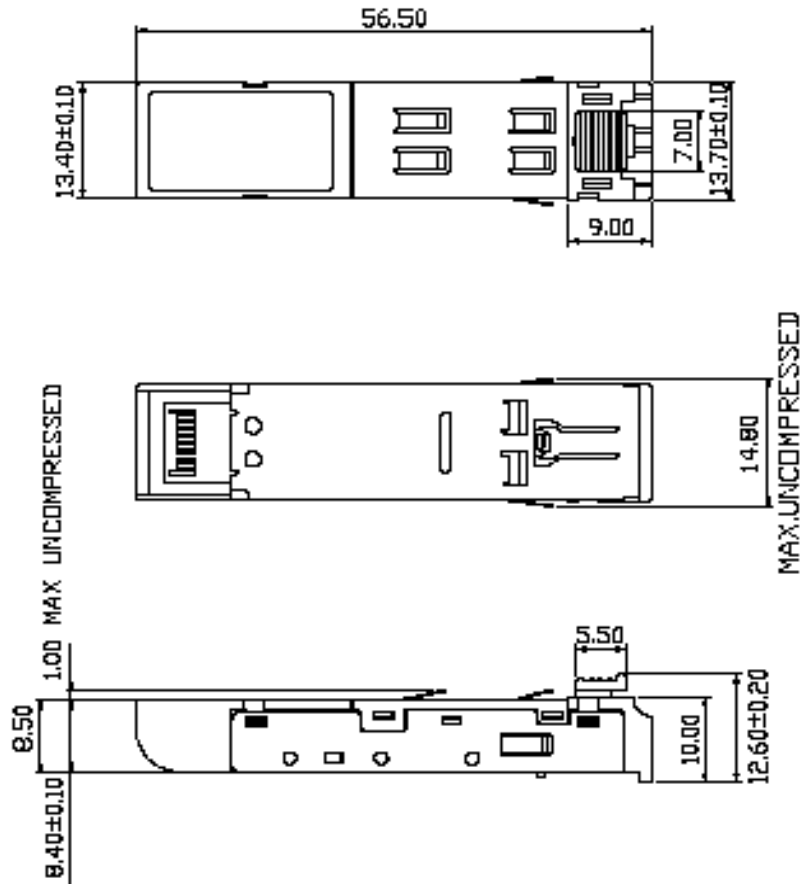

Ordering Information:

GSFP- 12 – X X X X X-2 X

